

aerospace
 climate control
 electromechanical
 filtration
 fluid & gas handling
 hydraulics
 pneumatics
 process control
 sealing & shielding

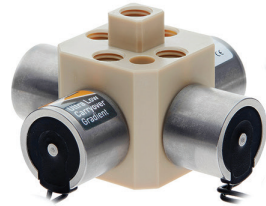

Miniature Liquid Control Valves

Precision Fluidics



ENGINEERING YOUR SUCCESS.

Innovative solutions for health care success















ENGINEERING **YOUR** SUCCESS.

When you partner with the global leader in motion and control technologies, expect to move your business and the world forward. From miniature solenoid valves to highly integrated automation systems, our innovations are critical to life-saving medical devices and scientific instruments used for drug discovery and pathogen detection. Not to mention, critical to decreasing time to market and lowering your overall cost of ownership. So partner with Parker, and get ready to move, well, anything.



www.parker.com/precisionfluidics 1 603 595-1500

Table of Contents

	Product		Page
	ULC Ultra Low Carryover	Media Isolated Miniature Liquid Valve Enabling increased instrument throughput and fluid circuit simplification	1
	ULCG Ultra Low Carryover Gradient	Media Isolated Miniature Liquid Valve Enables improved HPLC gradient accuracy and precision	11
	R9	9 mm Miniature Diaphragm Isolation Valve Easy mounting on 9 mm centers side to side, accommodating dispense over 96 well microplates	20
	C7	Miniature 7 mm Cartridge Liquid Valve	35
	C15	Miniature 15 mm Cartridge Liquid Valve	45
	C21	Miniature 21 mm Cartridge Liquid Valve	55
	Series 1 & 2	2-Way & 3-Way Inert Isolation PTFE Valve	65
	Series 3	2-Way & 3-Way General Purpose Valve	73
	Series 9	2-Way & 3-Way Extreme Performance Valve	83
	Series 99	Ultra Low Leak Extreme Performance Valve	94
	LQX12	12 mm Miniature Diaphragm Isolation Valve Designed to be Manifold Mounted Side-to-Side On 12 mm Centers	104
	Value Added	Application-Specific Solutions	116

Ultra Low Carryover Valve

Miniature Liquid Valve



Markets

- Clinical Diagnostics
- Analytical Chemistry
- Agent Detection
- Environmental Monitoring

Applications

- Sampling
- Reagent Addition
- Flow Control
- Gradient Proportioning

The Ultra Low Carryover Valve features both unrivaled low carryover and the ability to reduce fluidic circuit complexity by replacing multiple valves with a single valve. The valve uses a patent pending approach to increase throughput and decrease liquid waste by reducing wash times. Additionally, the Ultra Low Carryover Valve offers superior performance as a gradient proportioning valve for HPLC, HbA1c and other life science applications.

Features

Best in class low carryover performance

3 port valve offers four modes of operation: flow off, flow channel A, flow channel B, flow channel A + B.

Simplifies OEM instrument design by using fewer valves

Internal volume as low as 4.13 μL from common port to orifice seat

CE, IP-65 Rating, REACH and RoHS compliant



Product Specifications

Physical Properties

Valve Types:	
3 Ports with Four Modes	
2 Ports with Two Modes	
Porting:	
1/4 - 28 or Face Seal	
Media:	
Liquid	
Operating Environment/ Media Temperature:	
39°F to 122°F (4°C to 50°C)	
Storage Temperature:	
-4°F to 158°F (-20°C to 70°C)	
Weight:	
3 Port Face Seal:	1.06 oz (30.2 g)
2 Port Face Seal:	0.61 oz (17.3 g)
3 Port 1/4 - 28:	1.19 oz (33.7 g)
2 Port 1/4 - 28:	0.69 oz (19.6 g)

Electrical

Voltage (VDC):	12	24
Power (Watts):	3.0	3.0
Current (mA):	250	116
Resistance (Ohm):	48	207
$\Omega \pm 10\% @ 68^\circ\text{F}, 20^\circ\text{C}$ Note: For actuation exceeding 100ms Hit & Hold is required.		
Electrical Termination:	4.5 in (114.3 mm) Leads Terminated with Molex Housing #50-57-9402	

Wetted Materials*

Seals:	FFKM or EPDM
Body:	PEEK

Performance Characteristics

Leak Rate:		
0.15 sccm of Air		
Operating Pressure:		
45 psig (3.1 bar)		
Response Time:		
<10 msec at 20°C		
Recommended Filtration:		
16 μm or less		
Reliability:		
10 Million Cycles 0.95 Reliability Factor 95% Confidence Interval		
Internal Volume:		
Configuration	Port to Seat	Port to Port
3 Port Face Seal	12.54 μL	21.87 μL
2 Port Face Seal	11.36 μL	20.67 μL
3 Port 1/4 - 28	5.32 μL	15.43 μL
2 Port 1/4 - 28	4.05 μL	14.24 μL
Flow Rate:		
Minimum water flow of 320 mL/min @ 45 psig (3.1 bar)		

*Other materials available upon request

Ultra Low Carryover Valve Miniature Liquid Valve

Typical Flow Curve

Water Flow

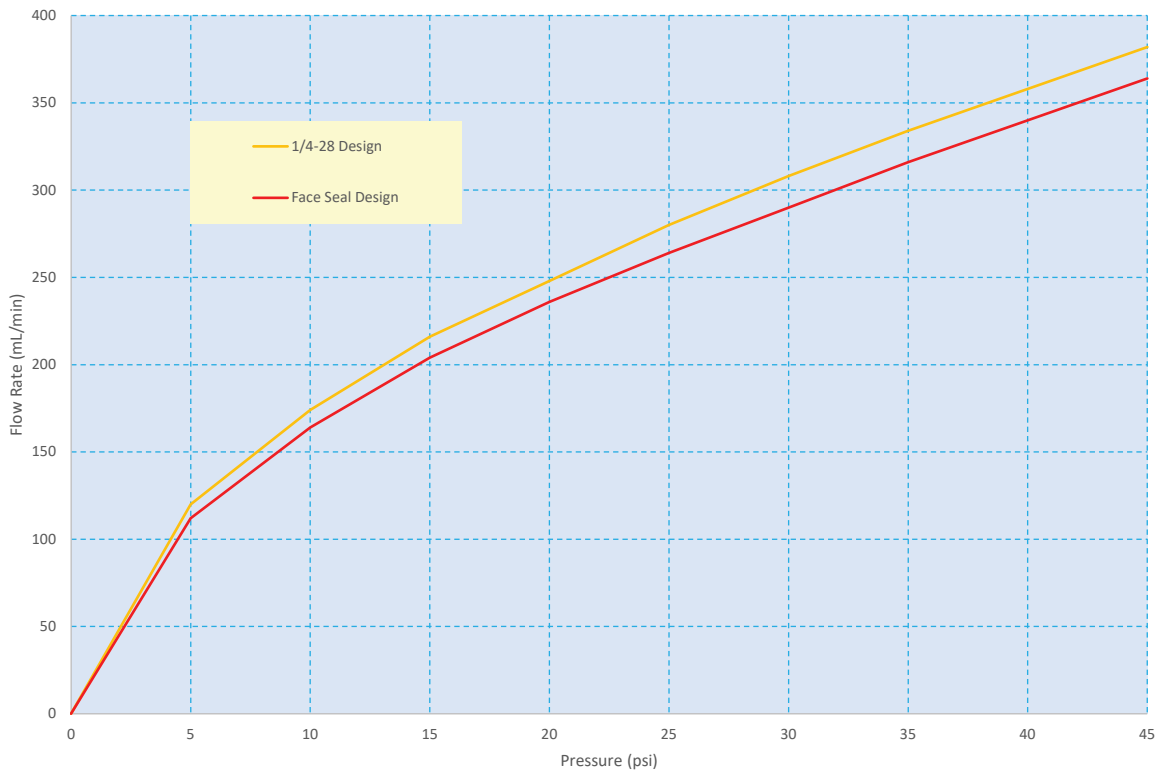

Electrical Interface

Wire Leads
 4.5 in (114.3 mm) \pm 0.25 in (6.35 mm)
 Terminated with Molex Housing #50-57-9402



Liquid Interface

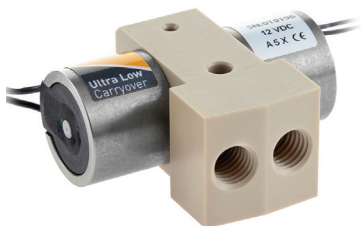

1/4 - 28 Design
 (Threaded Connectors)



Face Seal Design
 (Manifold Mount)

Ultra Low Carryover Valve Miniature Liquid Valve

Mechanical Integration

Dimensions

3 Port 1/4 - 28 Design

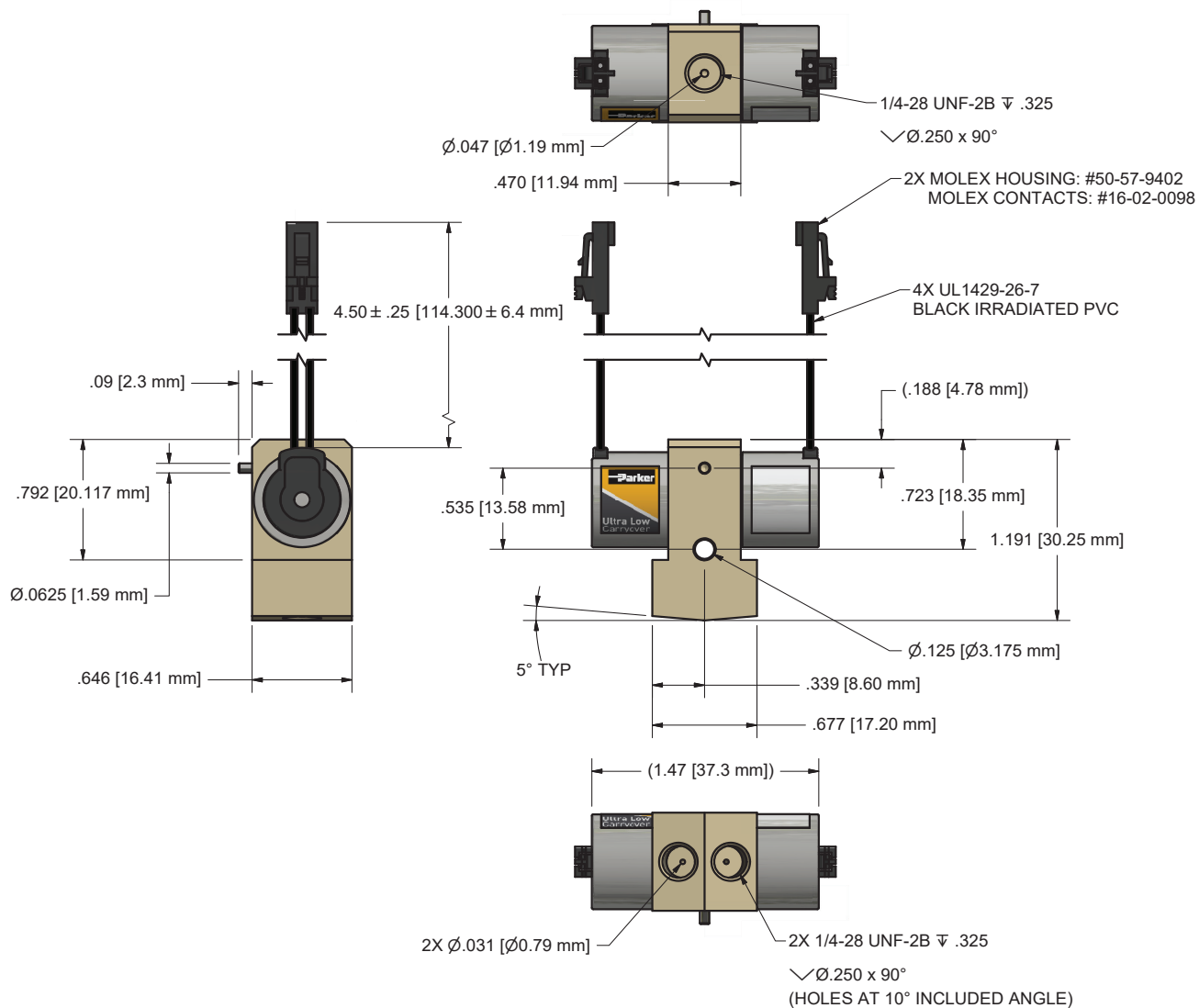

Ultra Low Carryover Valve Miniature Liquid Valve

Mechanical Integration Dimensions

3 Port Face Seal Design

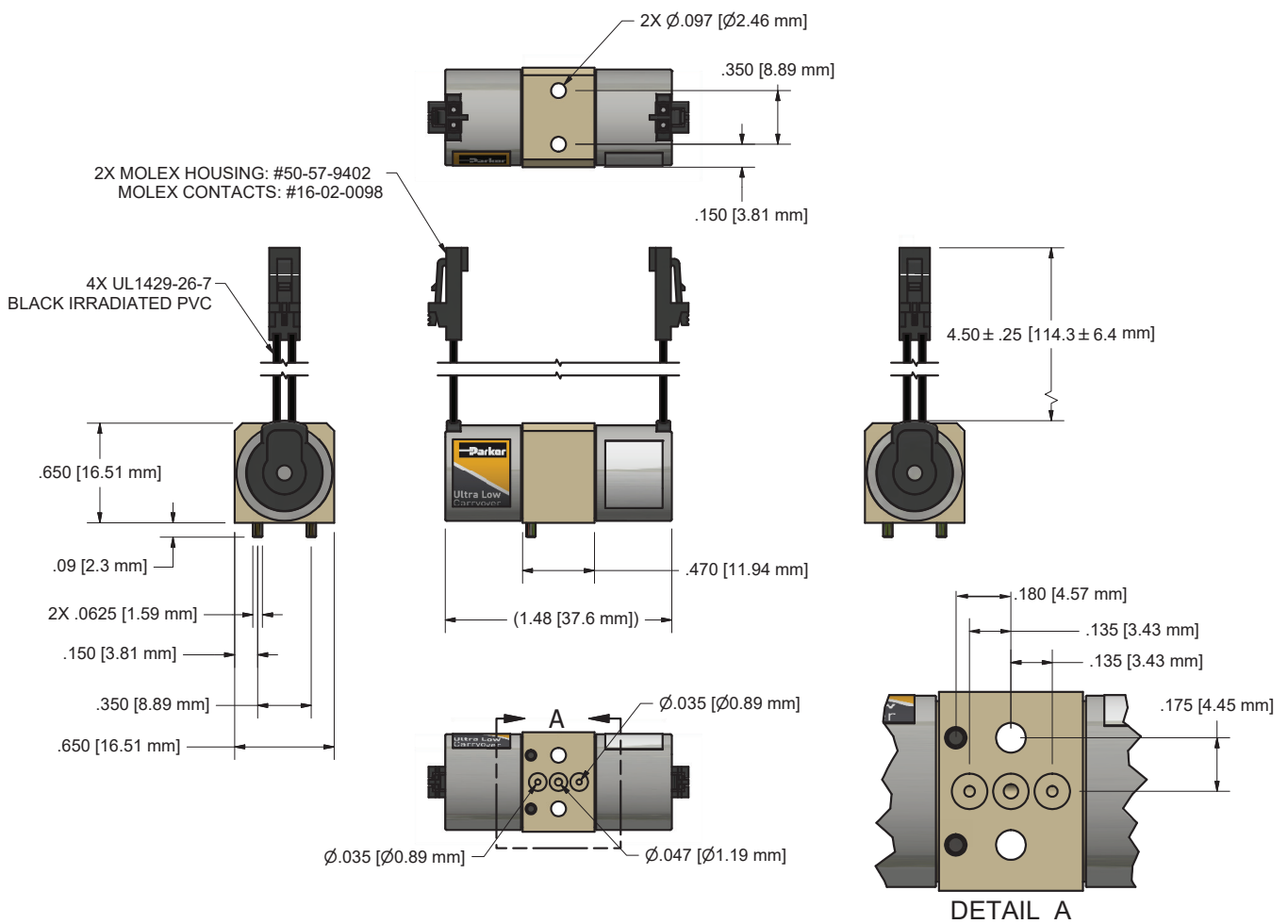

Ultra Low Carryover Valve Miniature Liquid Valve

Mechanical Integration Dimensions

2 Port 1/4 - 28 Design

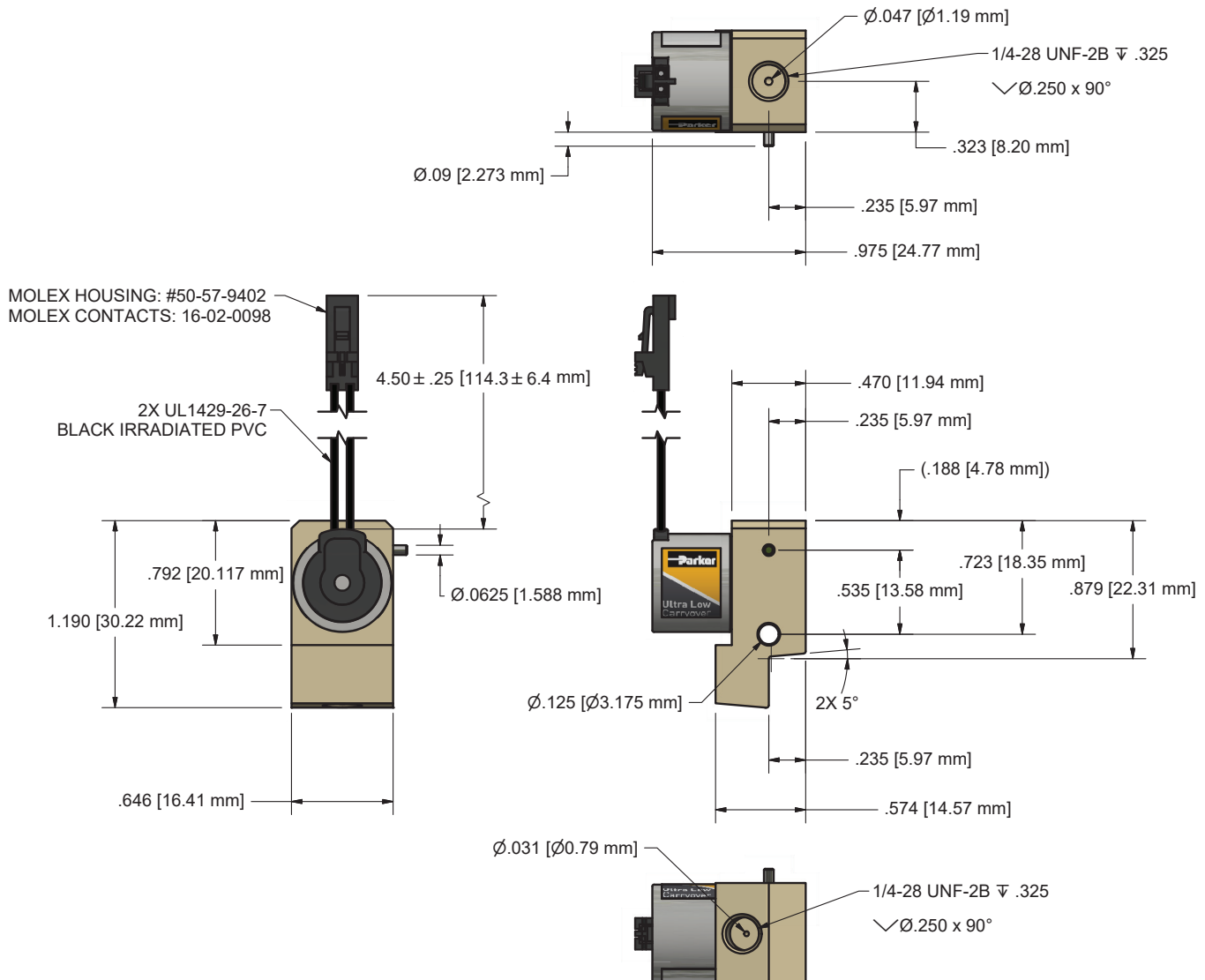

Ultra Low Carryover Valve Miniature Liquid Valve

Mechanical Integration Dimensions

2 Port Face Seal Design

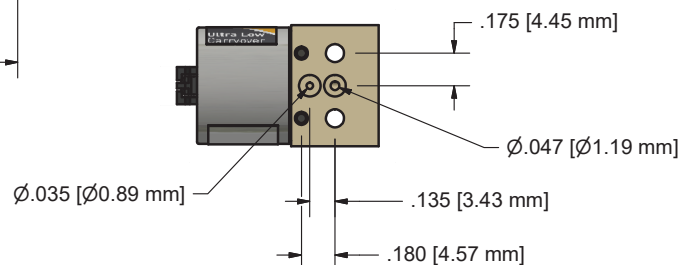
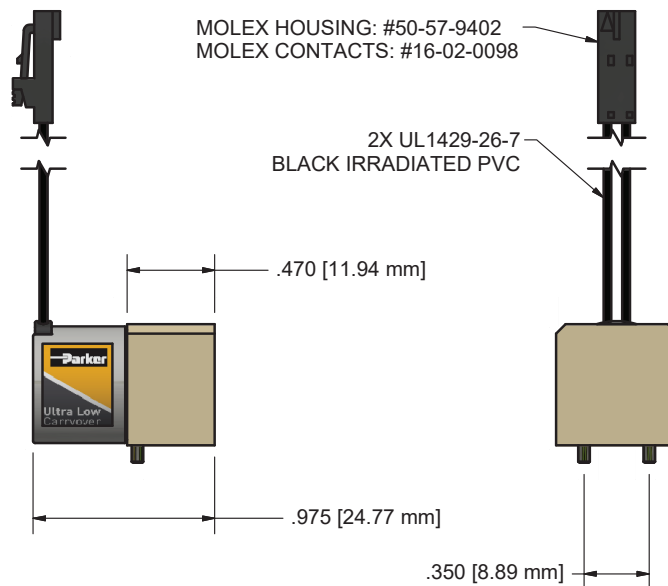
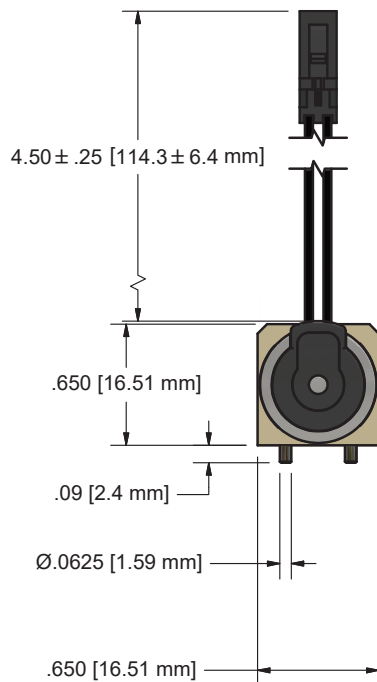
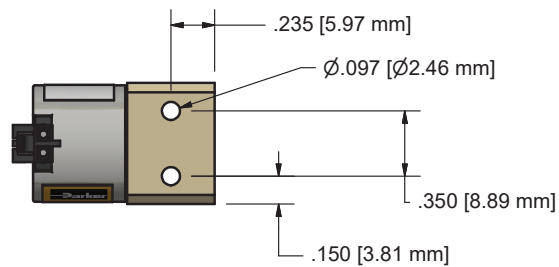

Ultra Low Carryover Valve Miniature Liquid Valve

Installation and Use

3 Port Manifold Interface

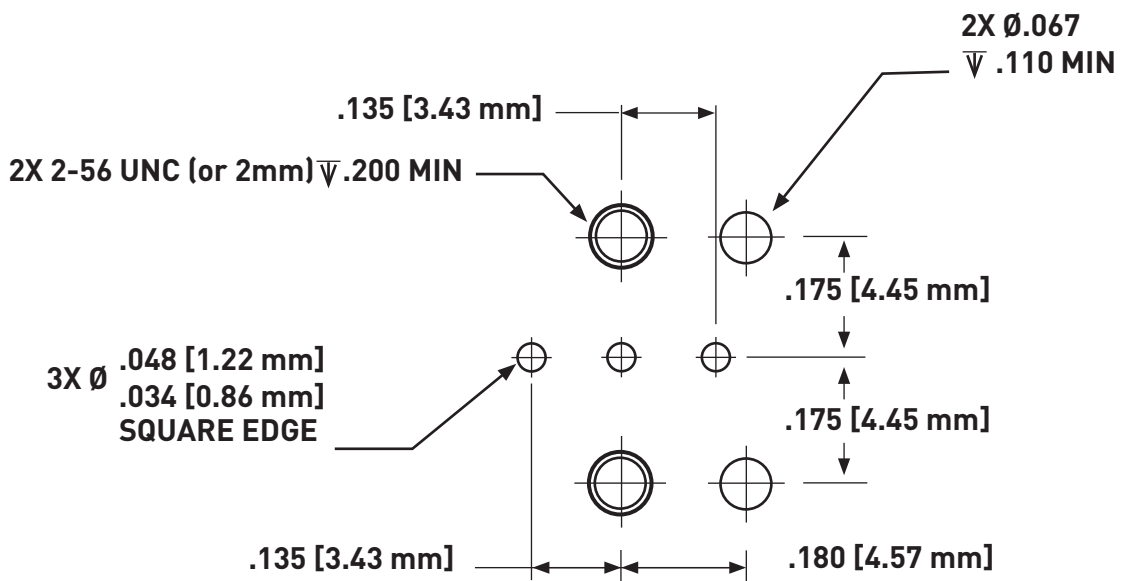

2 Port Manifold Interface

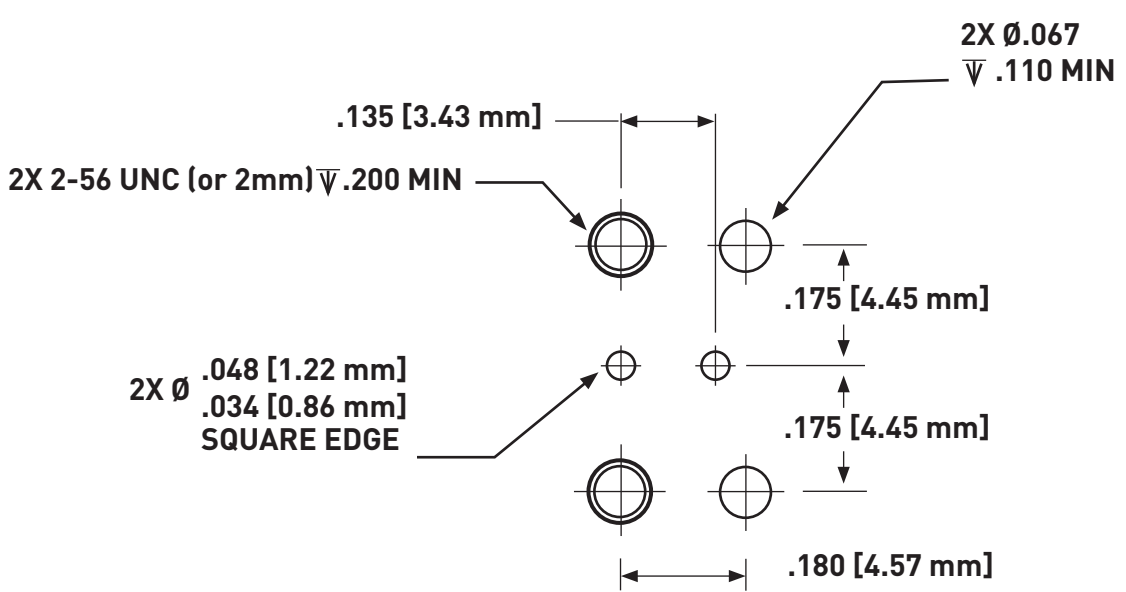

UNITS
IN. [mm]



Ultra Low Carryover Valve Miniature Liquid Valve

Hit and Hold Specifications

Hit and Hold is a method for driving valves that can be used to reduce power consumption and heat generation, while maintaining valve performance specifications. The valve is "hit" with the full rated voltage for a time period to open it (T1 in the graph) and then "held" open with substantially reduced voltage until the desired pulse length is reached (T2 in the graph). The following table shows the possible holding voltages and power consumption for our standard 12 and 24 VDC solenoids. A hit and hold circuit is required for use with actuation exceeding 100ms.

Rated Voltage (VDC)	Hold Voltage (VDC)	Typical Hold Power
24	12	0.7 watts
12	6	0.7 watts

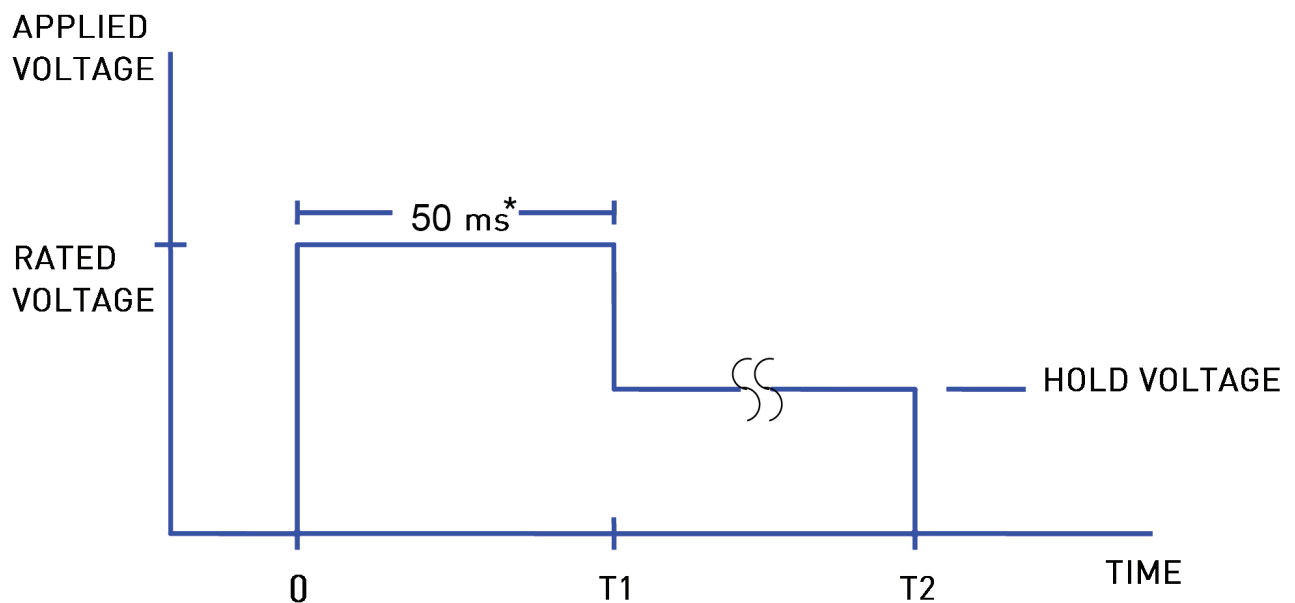

Hold Voltage Graph

* 50 ms recommended. Hit time shall be greater than 20 ms but not exceed 100 ms

Ultra Low Carryover Valve Miniature Liquid Valve

Chemical Compatibility Chart

Chemical	Diaphragm			Other Wetted Materials
	FFKM	or	EPDM	PEEK
DI Water	1		1	1
Methanol	1		1	1
Isopropanol	1		1	1
Ethanol	1		1	1
Acetonitrile	1		1	1
Tetrahydrofuran	2		4	1
Toluene	1		4	1
MEK	1		1	1
Organic Acids - Dilute	1		1	1
Non Organic Acids - Dilute	1		1	1
Bases - Dilute	1		1	1
Saline	1		1	1
Bleach 12%	2		1	1
Sodium Hydroxide 20%	1		1	1

Compatibility Legend

- EXCELLENT**
Minimal or no effect
- GOOD**
Possible swelling and or loss of physical properties
- DOUBTFUL**
Moderate or severe swelling and loss of physical properties
- NOT RECOMMENDED**
Severe effect and should not be considered

*The above is an Abbreviated Chemical Compatibility Chart. Please consult factory for additional information.

Regulatory CE
ENG61010 - 1:2010

IP-65 Rating - Contact Factory For Details

RoHS Directive Compliant - Contact Factory For Details 

REACH Compliant - Contact Factory For Details 

Ultra Low Carryover Valve Miniature Liquid Valve

Ordering Information



3 Port 1/4- 28 Design



3 Port Face Seal Design



2 Port 1/4- 28 Design



2 Port Face Seal Design

ULC	3	24	FF	3	F	F	-000
Series	Configuration	Voltage	Seal Manifold	Orifice	Mounting	Electrical Connection	Configuration
ULC-	2: 2 - Port 3: 3 - Port	12: 12 VDC 24: 24 VDC	FF: FFKM EP: EPDM	3: 0.030" (0.76mm)	F: Face Seal 4: 1/4 - 28	F: Latching Connector	-000
Accessories							
Part Number	Description	Comments					
890-001198-001	1/4 - 28 Female Threaded Face Seal Manifold	Allows connection of 1/4 - 28 fittings to Face Seal Design for bench testing					
191-000112-417	18 - 8 Stainless Steel Mounting Screws, #2-56 x 3/4						
290-006061-005	19.5 in (495.3mm) Wire Extension with Flying Leads						

NOTE: In order to provide the best possible solution for your application, please provide the following requirements when contacting Applications Engineering:

- Media, Inlet & Outlet Pressures
- Minimum Required Flow Rate
- System Supply Voltage
- Media and Media Temperature Range
- Ambient Temperature Range

For more detailed information, visit us on the Web, or call 603-595-1500.

Ultra Low Carryover Gradient Valve

Miniature Liquid Valve



Markets

- Analytical Chemistry
- Clinical Diagnostics
- Environmental Monitoring

Applications

- HPLC
- HbA1c
- Reagent Selection
- Distribution

The unique features of the Ultra Low Carryover Gradient Valve ensure high accuracy in gradient generation in quaternary HPLC designs. This is accomplished through a combination of quick response times and patented low volume well swept fluidic design. This miniaturized valve enables the reduction of overall instrument size and decreases system dead volume. Exceptional long life and crystallization resistance ensures that the valve will last the life of the instrument.

Features

Internal volume as low as 4.05 μL (2-channel) and 9.4 μL (4-channel) from seat to port

Very low response time of 2 ms improves gradient precision

Patent pending design accelerates change between channels

80% smaller and 75% lighter than competing valves

Minimized pumping volume

REACH and RoHS compliant



Product Specifications

Physical Properties

Valve Type:	
4-Channel & 2-Channel	
Media:	
Liquid	
Operating Environment/ Media Temperature:	
4°C to 50°C (39°F to 122°F)	
Storage Temperature:	
-20°C to 70°C (-4°F to 158°F)	
Weight:	
4-Channel Radial Design	2.56oz (72.5g)
4-Channel Panel Mount	2.45oz (69.5g)
2-Channel Design	1.19oz (33.7g)
Porting:	
1/4-28	
Internal Volume: (seat to common port)	
4-Channel Radial Design	9.4 μL
4-Channel Panel Mount	12.99 μL
2-Channel Design	4.05 μL
Orifice Size:	
.030" (0.76 mm)	

Electrical

Voltage (VDC \pm):	12	24
Power (Watts):	3.0	3.0
Current (mA):	250	116
Resistance (Ohm):	48	207
$\Omega \pm 10\% @ 68^\circ\text{F}, 20^\circ\text{C}$ Note: For actuation exceeding 100ms Hit & Hold is required.		
Electrical Termination:	Molex Housing: #50-57-9402 Molex Contacts: #16-02-0098	

Wetted Materials*

Seals:	FFKM or EPDM
Body:	PEEK
Regulatory:	RoHS directive (2002/95/EC) and REACH EC 1907/2006
Mounting Options:	1/4-28 Threaded Female Design

Performance Characteristics

Leak Rate:	0.150 sccm of Air (bubble tight)
Operating Pressure:	45 psig (3.1 bar)
Proof Pressure:	120 psig (8.3 bar)
Response Time:	<2 msec at 2X rated Voltage <10 msec at rated Voltage
Recommended Filtration:	16 μm
Reliability:	50 Million Cycles
Flow Rate:	Minimum water flow of 320 mL/ min @ 45 psig (3.1 bar)

*Other materials available upon request



Ultra Low Carryover Gradient Valve Miniature Liquid Valve

Typical Flow Curve

Water Flow

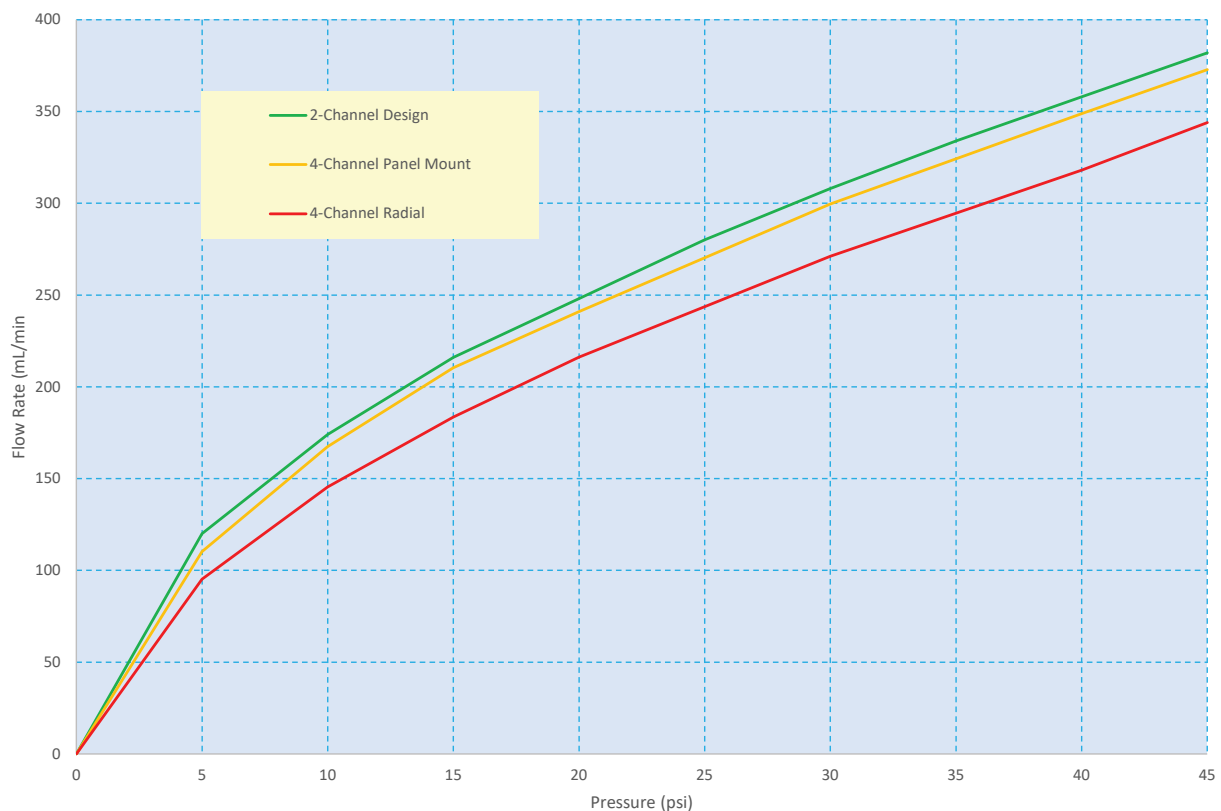

Electrical Interface

Wire Leads
 4.5 in (114.3 mm) \pm 0.25 in (6.35 mm)
 Terminated with Molex Housing #50-57-9402



Liquid Interface

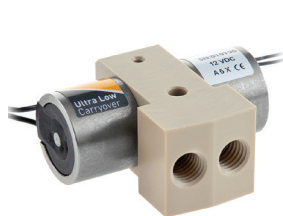

1/4 - 28 Design
 (Threaded Connectors)

Ultra Low Carryover Gradient Valve Miniature Liquid Valve

Mechanical Integration Dimensions

4-Channel Radial Design

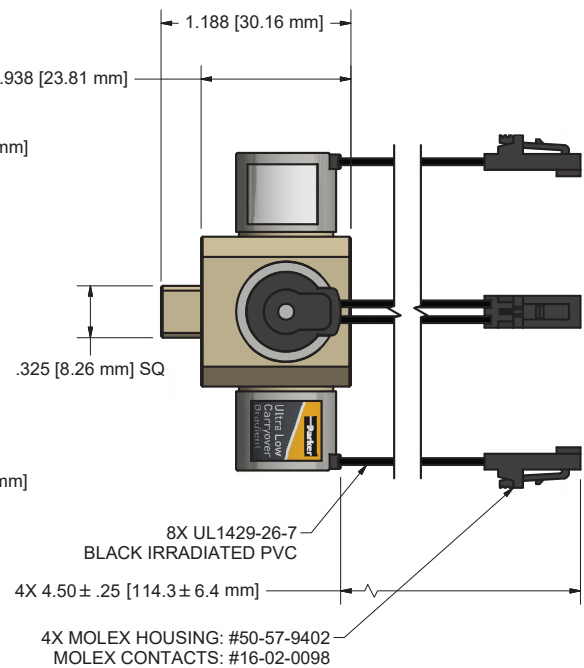
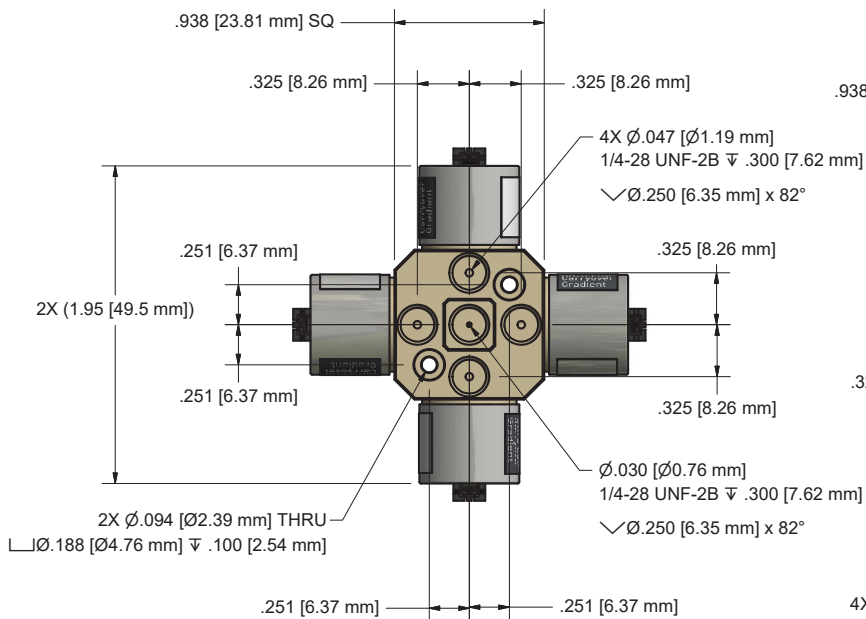
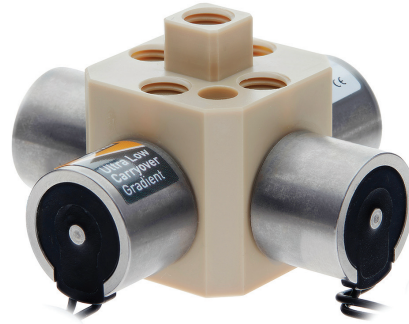

Ultra Low Carryover Gradient Valve Miniature Liquid Valve

Mechanical Integration

Dimensions

4-Channel Panel Mount

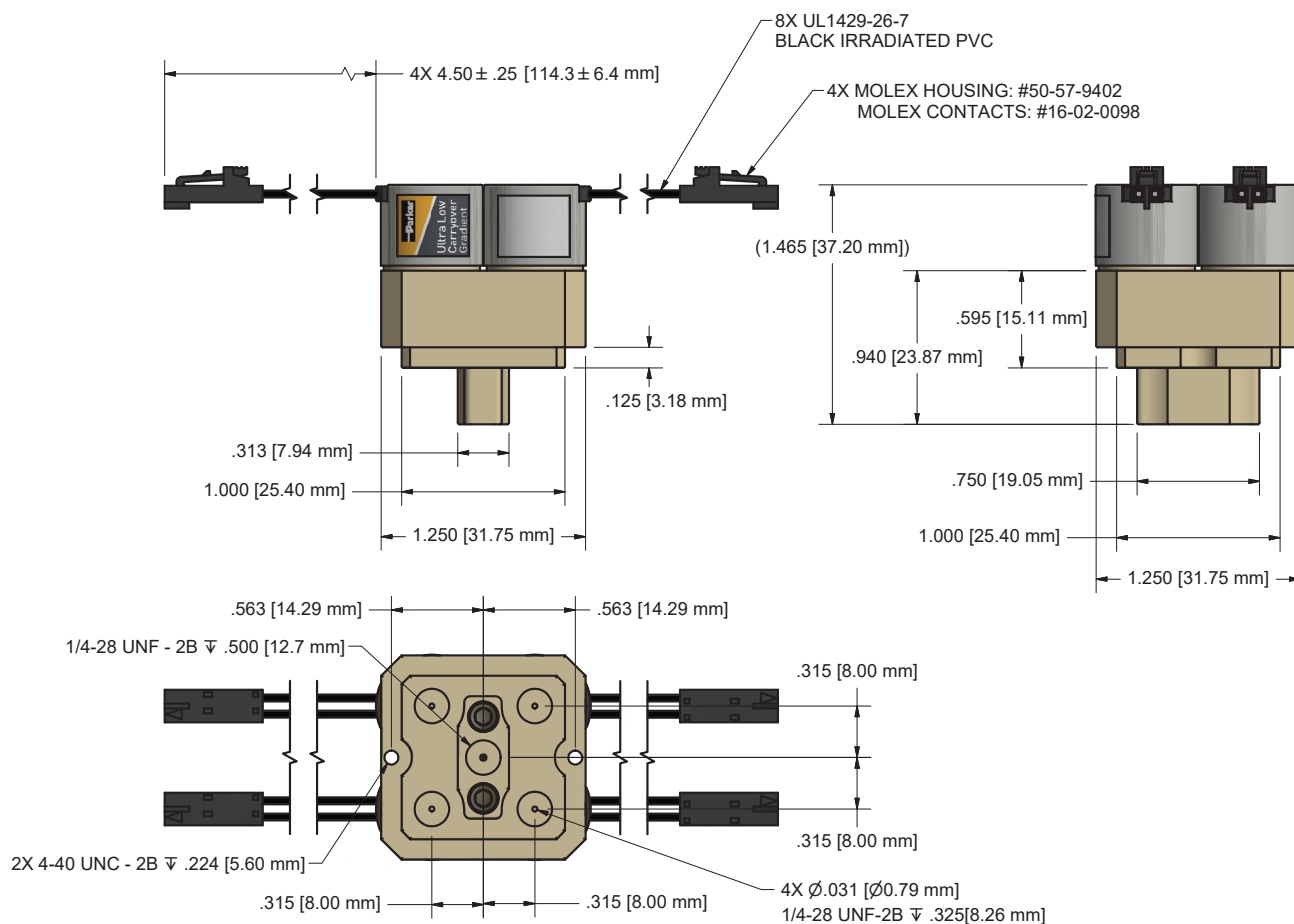
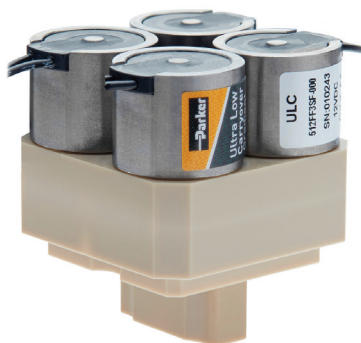

Ultra Low Carryover Gradient Valve Miniature Liquid Valve

Mechanical Integration Dimensions

2-Channel Design

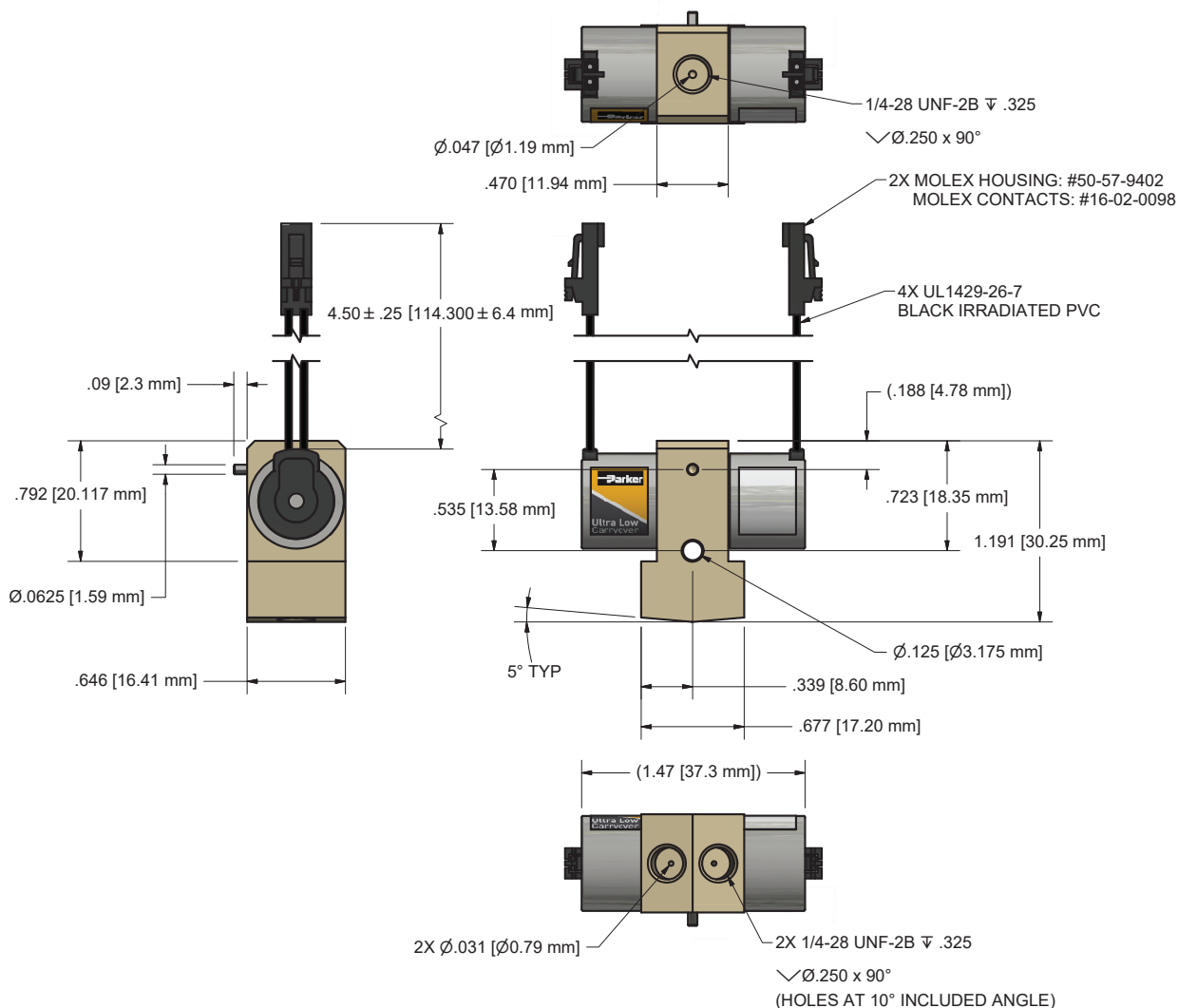

Ultra Low Carryover Valve Gradient Miniature Liquid Valve Typical Flow Diagram

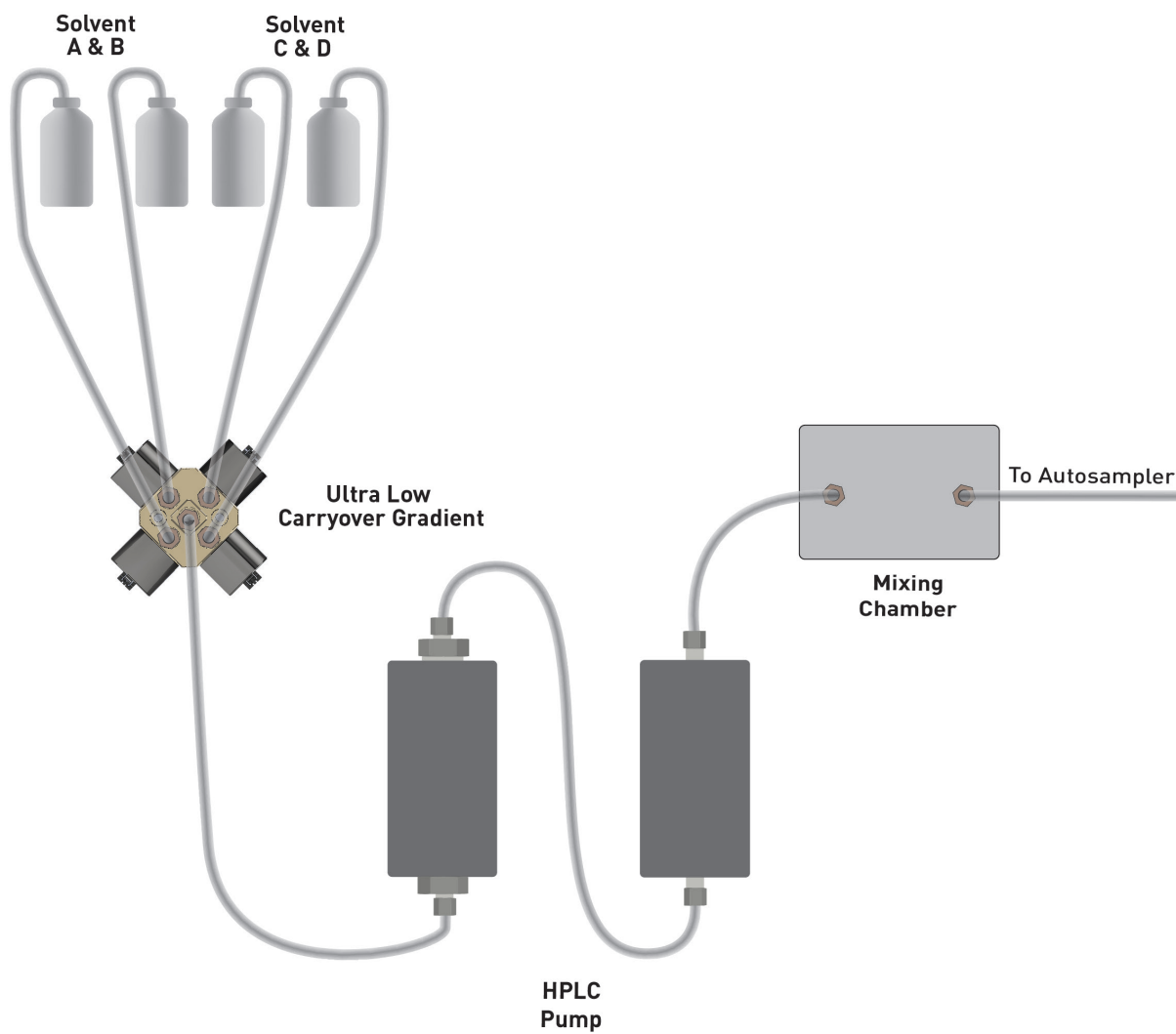

Ultra Low Carryover Gradient Valve Miniature Liquid Valve

Hit and Hold Specifications

Hit and Hold is a method for driving valves that can be used to reduce power consumption and heat generation while maintaining valve performance specifications. The valve is "hit" with the full rated voltage for some time period to open it (T1 in the graph) and then "held" open with substantially reduced voltage until the desired pulse length is reached (T2 in the graph). The following table shows the possible holding voltages and power consumption for our standard 12 and 24 VDC solenoids. A hit and hold circuit is required for use with actuation exceeding 100ms.

Rated Voltage (VDC)	Hold Voltage (VDC)	Typical Hold Power
24	12	0.75 watts
12	6	0.70 watts

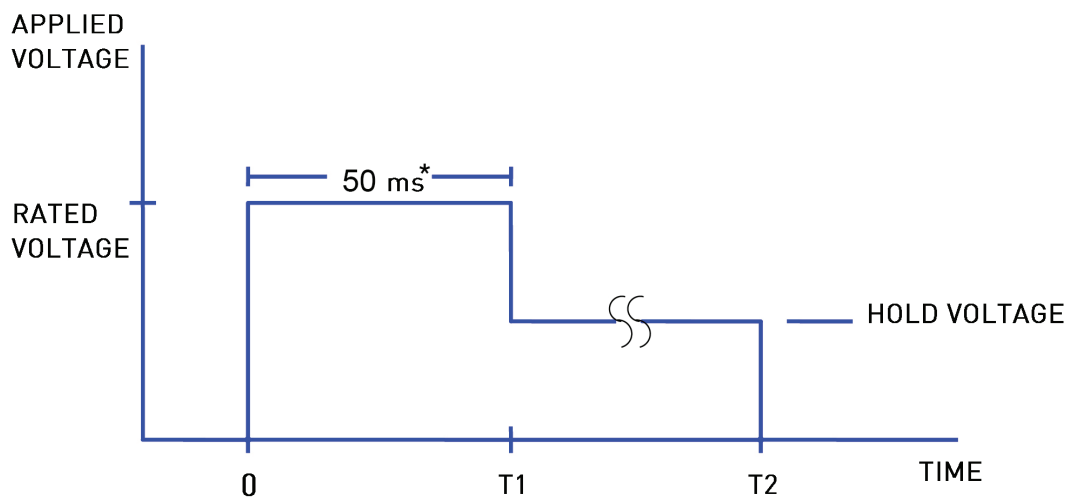

Hold Voltage Graph

* 50 ms recommended. Hit time shall be greater than 20 ms but not exceed 100 ms

Ultra Low Carryover Gradient Valve Miniature Liquid Valve Chemical Compatibility Chart

Chemical	Diaphragm			Other Wetted Materials
	FFKM	or	EPDM	PEEK
DI Water	1		1	1
Methanol	1		1	1
Isopropanol	1		1	1
Ethanol	1		1	1
Acetonitrile	1		1	1
Tetrahydrofuran	2		4	1
Toluene	1		4	1
MEK	1		1	1
Organic Acids - Dilute	1		1	1
Non Organic Acids - Dilute	1		1	1
Bases - Dilute	1		1	1
Saline	1		1	1
Bleach 12%	2		1	1
Sodium Hydroxide 20%	1		1	1

Compatibility Legend

- EXCELLENT**
Minimal or no effect
- GOOD**
Possible swelling and or loss of physical properties
- DOUBTFUL**
Moderate or severe swelling and loss of physical properties
- NOT RECOMMENDED**
Severe effect and should not be considered

*The above is an Abbreviated Chemical Compatibility Chart. Please consult factory for additional information.

Regulatory C€

ENG61010 - 1:2010

IP-65 Rating - IEC/EN 60529:2013

RoHS Directive Compliant - Contact Factory For Details 

REACH Compliant - Contact Factory For Details 

Ultra Low Carryover Gradient Valve Miniature Liquid Valve

Ordering Information



4-Channel Panel Mount



4-Channel Radial Design



2-Channel Design

ULC	3	24	FF	3	R	F	-000
Series	Configuration	Voltage	Seal Manifold	Orifice	Mounting	Electrical Connection	Configuration
ULC-	3: 2-Channel	12: 12 VDC 24: 24 VDC	FF: FFKM EP: EPDM	3: 0.030" (0.76mm)	4: 1/4 - 28	F: Latching Connector	-000
ULC-	5: 4-Channel	12: 12 VDC 24: 24 VDC	FF: FFKM EP: EPDM	3: 0.030" (0.76mm)	S: Panel Mount 1/4-28 R: Radial Body 1/4-28	F: Latching Connector	-000
Accessories							
Part Number			Description				
290-006061-005			19.5 in (495.3mm) Wire Extension with Flying Leads				

NOTE: In order to provide the best possible solution for your application, please provide the following requirements when contacting Applications Engineering:

- Media, Inlet & Outlet Pressures
- Minimum Required Flow Rate
- System Supply Voltage
- Media and Media Temperature Range
- Ambient Temperature Range

For more detailed information, visit us on the Web, or call 603-595-1500.

R9 Valve

9 mm Miniature Diaphragm Isolation Valve



Markets



- Clinical Diagnostics
- Analytical Chemistry
- Agent Detection
- Environmental Monitoring

Applications

- Sampling
- Reagent Addition
- Flow Control
- Wash
- Waste

The R9 delivers the liquid flow capabilities of a 16 mm valve with a 9 mm envelope. A 44% reduction in width with unrivaled flows and pressures to 100 psi. Designed to offer low carryover performance with particulate and crystallization resistance, this valve is ideally suited for today's demanding liquid handling applications. The R9 supports the performance requirements of current and future laboratory and portable instrumentation.

Features

- High pressure options available up to 100 PSI (6.9 bar)
- Easy mounting on 9 mm centers side to side, accommodating dispense over 96 well microplates
- Low unswept volume to minimize carryover
- Particulate and crystallization resistant
- 100% tested leak rate ensures a leak tight seal on every valve
- CE, REACH, and RoHS compliant   

Product Specifications

Physical Properties

Valve Type:	Diaphragm Rocker Isolation Valve
Valve Configuration:	3-Way Universal 2-Way Normally Closed
Media: Liquids	
Operating Environment/ Media Temperature:	EPDM 32 to 122F (0 to 50c) FFKM High Pressure (100psi, 40psi versions) 50 to 122F(10-50c) FFKM Standard Pressure (60psi, 20psi versions) 59 to 122F (15-50c)
Storage Temperature:	-4 to 158°F (-20 to 70°C)
Dimensions:	Width: 0.34" (8.7 mm) Depth: 1.46" (37 mm) Length: 2.71" (68.8 mm)
Weight:	Face Seal Version: 1.35 oz. (38.4g) 1/4-28 or M6 version: 1.63 oz. (46.1g)
Porting:	Face Seal, 1/4-28 & M6
Internal Volume:	Face Seal: 39.4µL 1/4-28 or M6: 116.6µL

Electrical

Voltage (VDC): 12 and 24 VDC ± 5%									
Orifice:		0.030" (0.76 mm)				0.061" (1.55 mm)			
MAX PRESSURE	PSI	Vac to 100*		Vac to 60		Vac to 40*		Vac to 20	
	BAR	Vac to 6.9*		Vac to 4.1		Vac to 2.8*		Vac to 1.4	
POWER (WATTS)		12V	24V	12V	24V	12V	24V	12V	24V
	HIT	7.1*		4.5 4.8		7.1*		4.5 4.8	
	HOLD	1.8		1.1 1.2		1.8		1.1 1.2	
Max (mA):		592	296	375	200	592	296	375	200
Resistance: (Ohms)**:		20.5	81	32	120	20.5	81	32	120
Connections:									
2.54 mm pitch male pins, 18" (46 cm) Flying Lead Connector									
*Requires hit and hold circuit									
**(Ω±5% @ 68°F, 20°C)									

Wetted Materials*

Seals:	EPDM or FFKM
Base:	PEEK (polyetheretherketone)
1/4-28 / M6 Sub Base Manifold	PEEK (polyetheretherketone)
* See Chemical Compatibility Page Consult factory for other options	

Performance Characteristics

Operating Proof Pressure:	Face Seal 200 PSI (13.8 bar) 1/4-28 and M6 150 PSI (10.3 bar)
Leak Rate:	Bubble Tight
Response Time:	18 msec max
Recommended Filtration:	5 µm
Reliability:	10 Million Cycles

R9 Miniature Diaphragm Isolation Valve

Typical Flow Curve

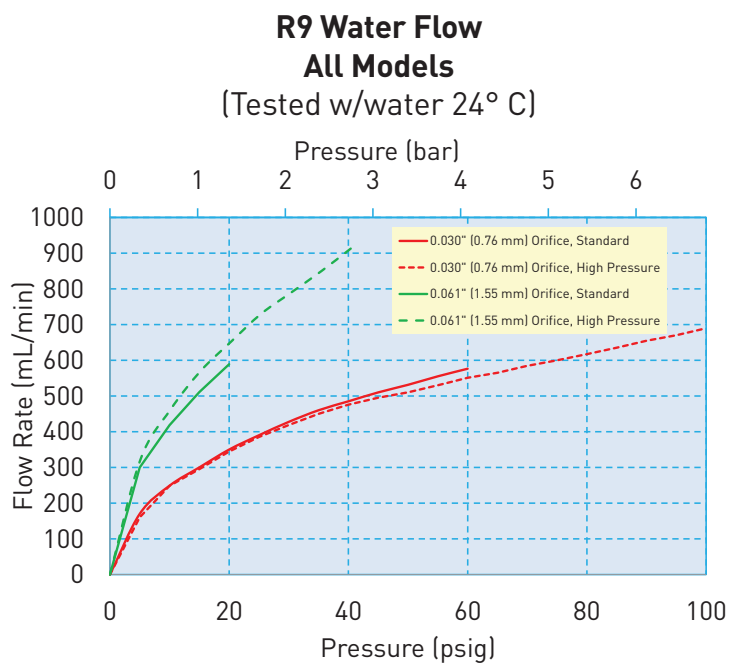

Electrical Interface



Male Pins
(2.54 mm pitch male pins)



Wire Leads*
18" (46 cm)

*Custom lead length available.

Liquid Interface



Face Seal
(Manifold Mount)



1/4 - 28 Ports
(Threaded Connector)



M6 Ports
(Threaded Connector)

Locator pins help prevent mounting the valve backwards and ensure proper alignment of the ports to the fluid passageways in the manifold. Pins prevent a 2-way valve from being mounted in the place of a 3-way valve and vice versa.
Molex® Connector Female P/N 22-01-2027 / Molex® Terminal Crimp Socket P/N 08-52-0105 or P/N 08-52-0106

R9 Miniature Diaphragm Isolation Valve



R9

Footprint Comparison to 16 mm Valve

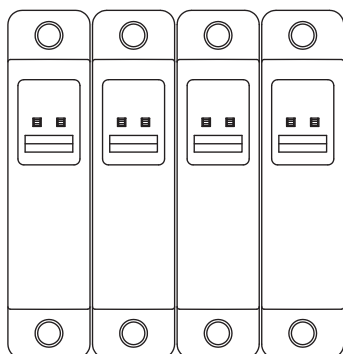

FOOTPRINT OF 4 R9 VALVES

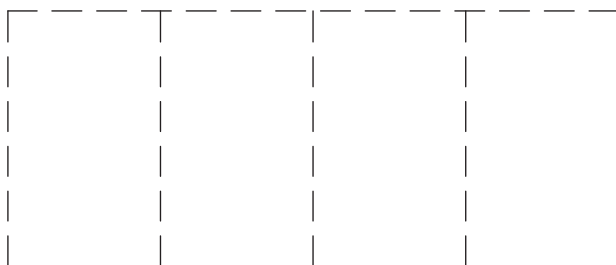

FOOTPRINT OF 4 16mm VALVES

44% REDUCTION IN
WIDTH RESULTS IN 39%
REDUCTION IN AREA

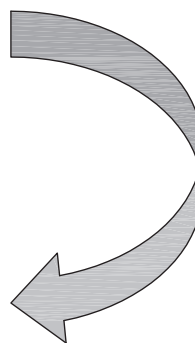

R9 Miniature Diaphragm Isolation Valve

Mechanical Integration

Dimensions

2-Way Dimensions

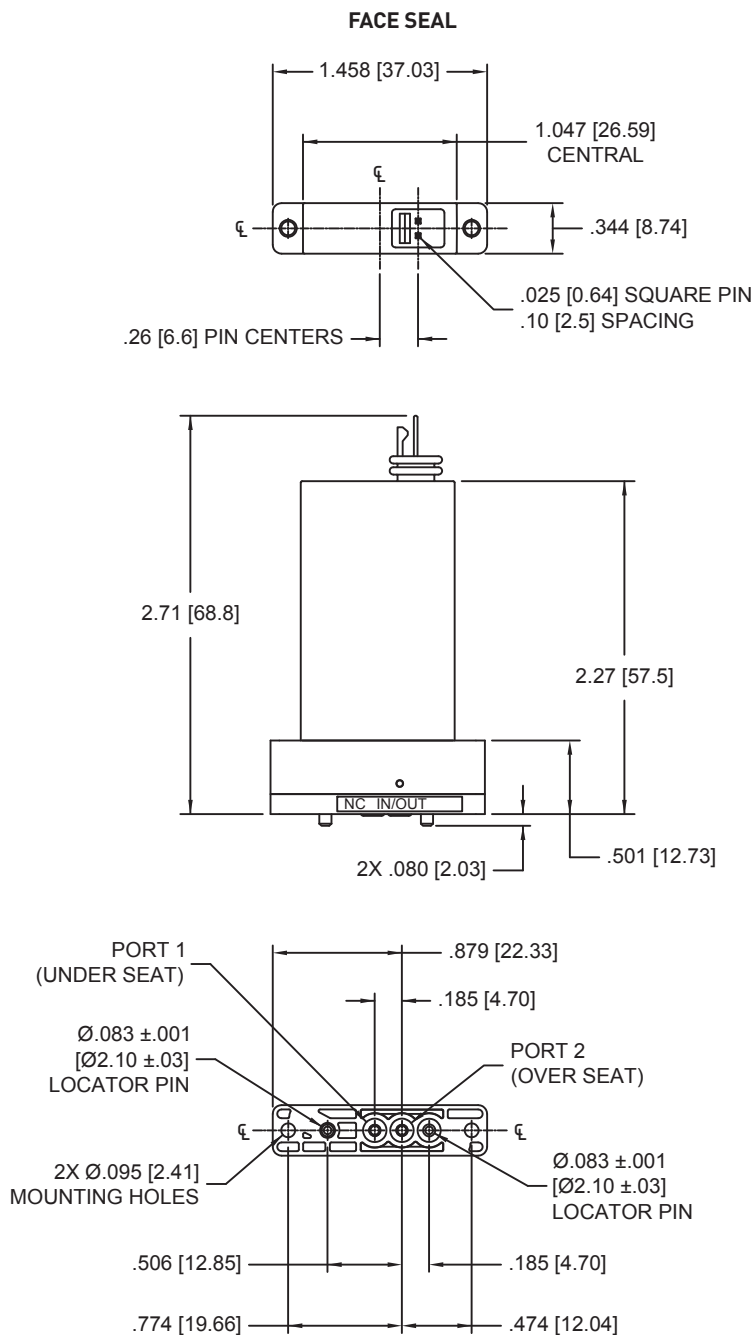

UNITS
IN. [mm.]

R9 Miniature Diaphragm Isolation Valve

Mechanical Integration

Dimensions

2-Way Dimensions

1/4-28 OR M6 SUB BASE

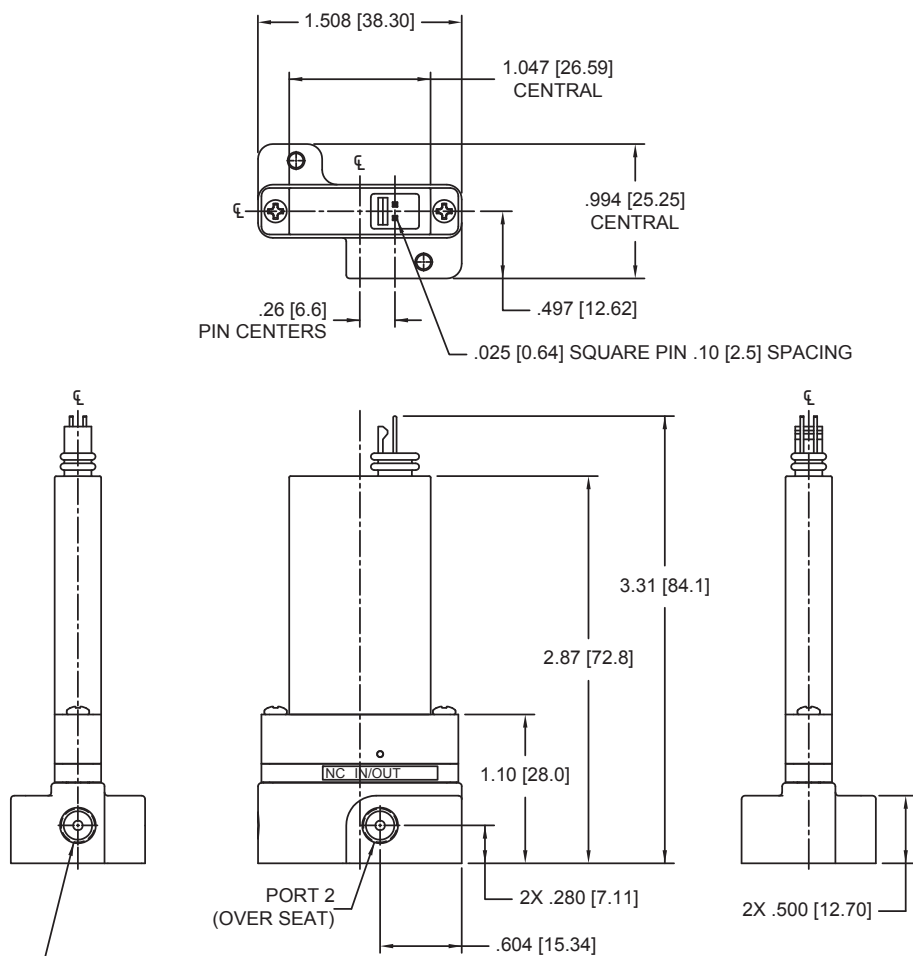

FLAT BOTTOM PORTS
 2X 1/4-28 UNF-2B ∇ .320 \pm .002 MIN .24 THREAD DEPTH
 OR [M6X1 - 6H ∇ 8.89 \pm 0.05 MIN 7.1] THREAD DEPTH
 PORT 1 (UNDER SEAT)

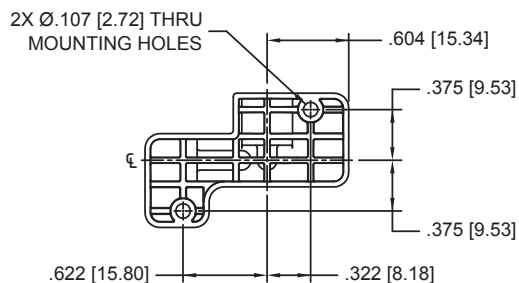

UNITS
IN. [mm.]

R9 Miniature Diaphragm Isolation Valve

Mechanical Integration Dimensions

3-Way Dimensions

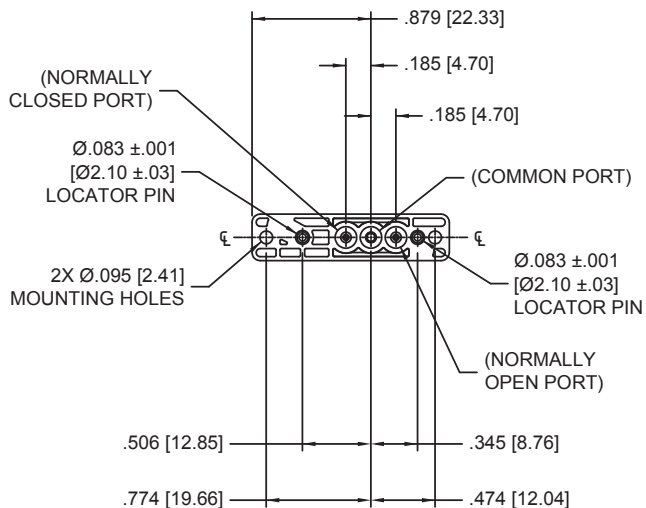
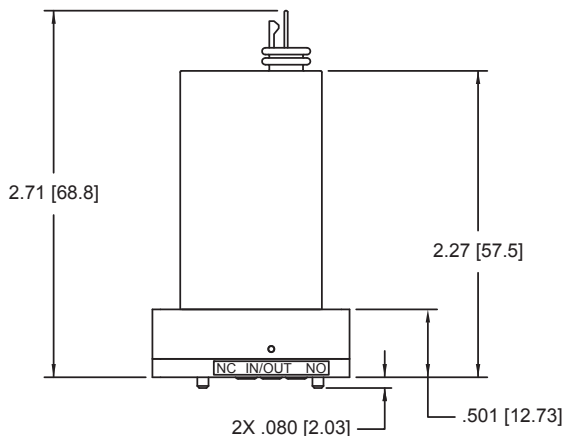
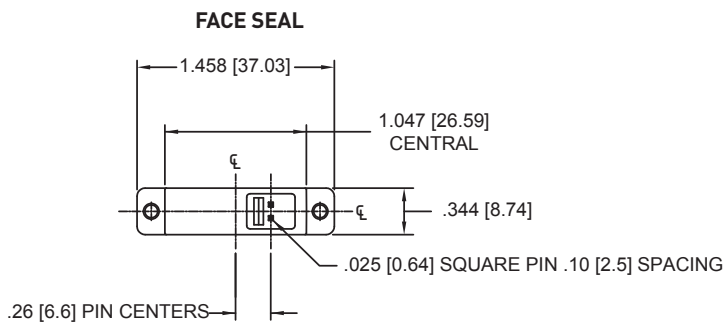

UNITS
IN. [mm.]

R9 Miniature Diaphragm Isolation Valve

Mechanical Integration

Dimensions

3-Way Dimensions

1/4 -28 OR M6

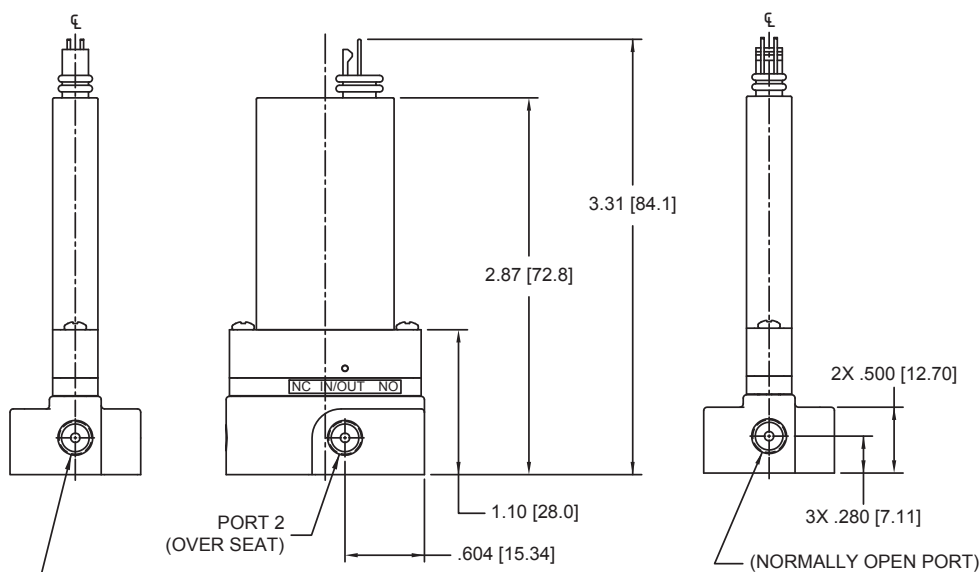
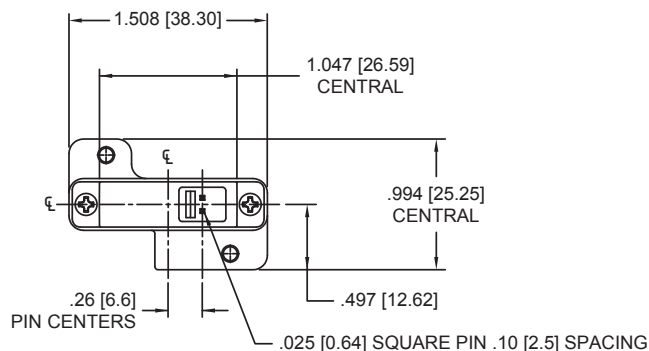

FLAT BOTTOM PORTS
2X 1/4-28 UNF-2B ∇ .320 \pm .002 MIN .24 THREAD DEPTH
OR [M6X1 - 6H ∇ 8.89 \pm 0.05 MIN 7.1] THREAD DEPTH
PORT 1 (UNDER SEAT)

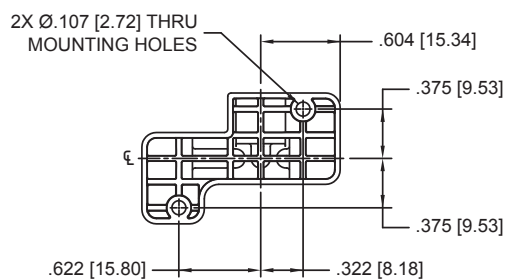

UNITS
IN. [mm.]

R9 Miniature Diaphragm Isolation Valve

Installation and Use

R9 Manifold Interface Recommended R9 Valve Mounting

R9 2-WAY MANIFOLD INTERFACE

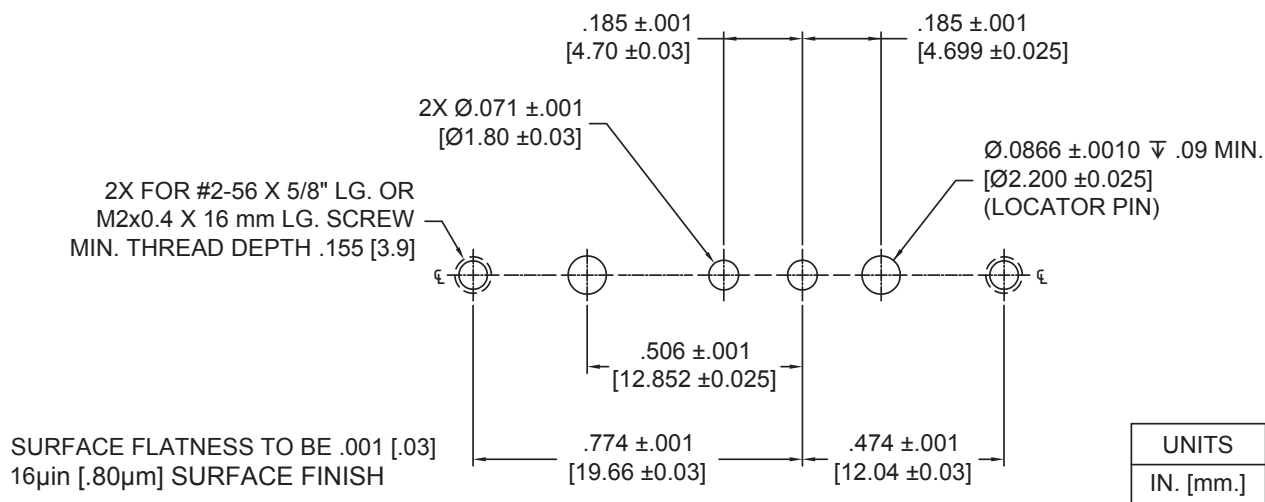

R9 3-WAY MANIFOLD INTERFACE

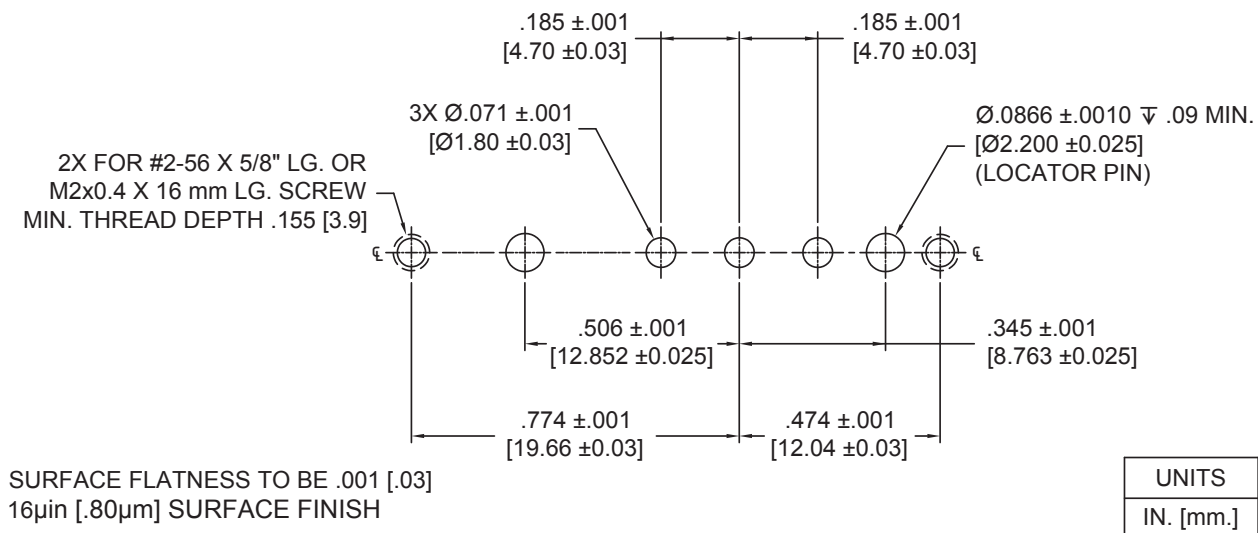

R9 Miniature Diaphragm Isolation Valve

ANSI Symbols

Vacuum

ANSI SYMBOLS 2-WAY

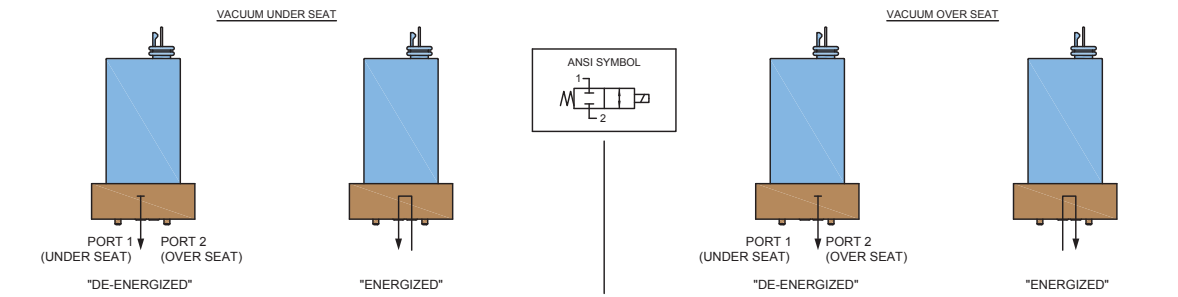

3-WAY

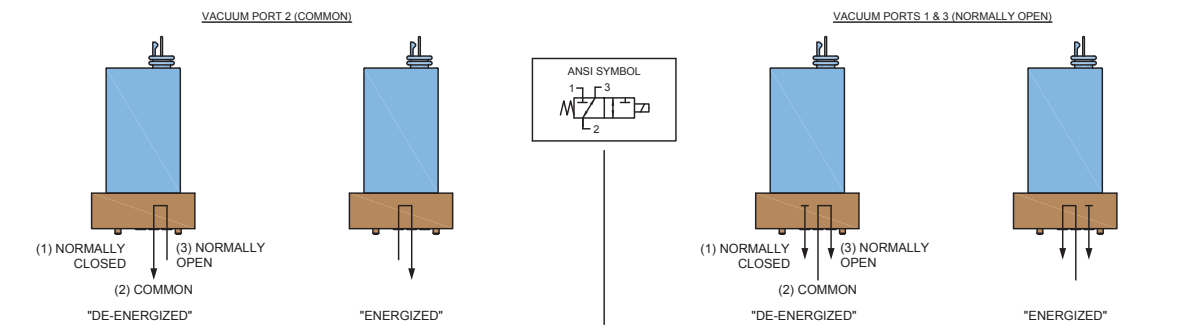

2-WAY 1/4-28 OR M6 PORTS

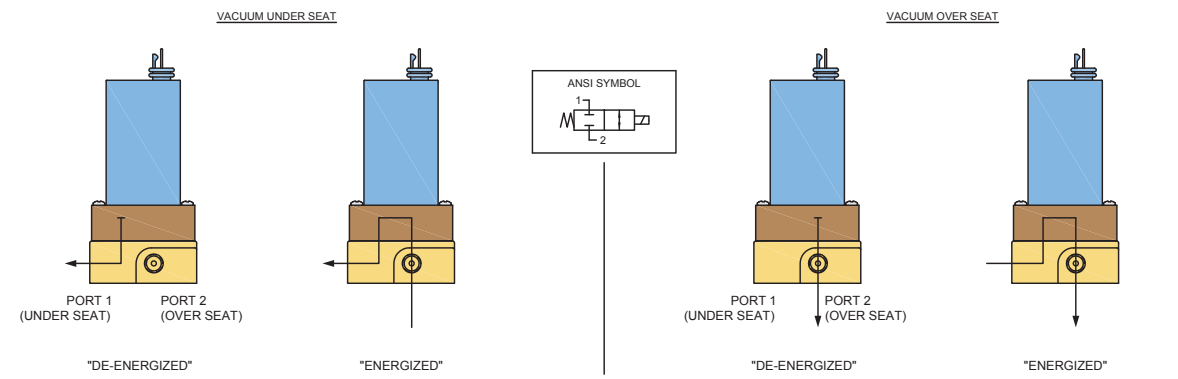

3-WAY 1/4-28 OR M6 PORTS

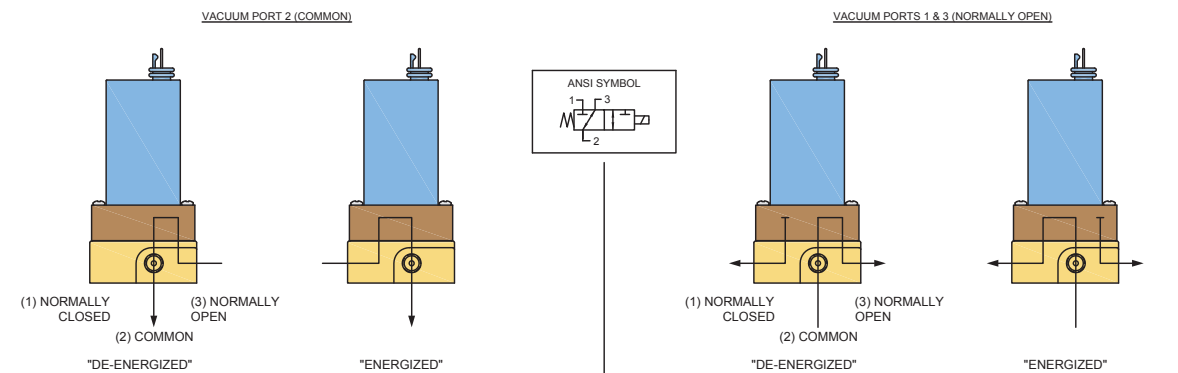

R9 Miniature Diaphragm Isolation Valve

Hit and Hold Specifications

Hit and Hold is a method for driving valves that can be used to reduce power consumption and heat generation while maintaining valve performance specifications. The valve is "hit" with the full rated voltage for some time period to open it (T1 in the graph) and then "held" open with substantially reduced voltage until the desired pulse length is reached (T2 in the graph). The following table shows the possible holding voltages and power consumption for our standard 12 and 24 VDC solenoids. A hit and hold circuit is required for use with the high pressure version.

Rated Voltage (VDC)	High Pressure Versions* 100 PSI (6.9 bar) & 40 PSI (2.8 bar) Max		Standard Versions 60 PSI (4.1 bar) & 20 PSI (1.4 bar) Max	
	Hold Voltage	Hold Power	Hold Voltage	Hold Power
24	12VDC	1.8 watts	12VDC	1.2 watts
12	6VDC	1.8 watts	6VDC	1.1 watts

*Requires hit and hold circuit

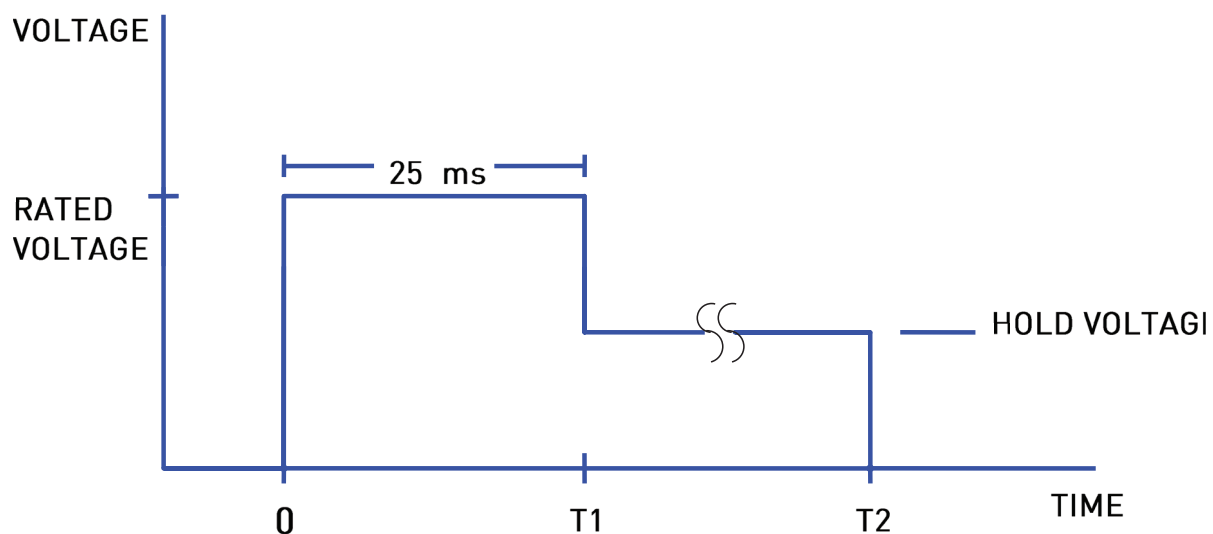

Hold Voltage Graph

R9 Miniature Diaphragm Isolation Valve

Chemical Compatibility Chart*

Chemical	Diaphragm		Other Wetted Materials	
	FFKM	or	EPDM	PEEK
DI Water	1		1	1
Methanol	1		1	1
Isopropanol	1		1	1
Ethanol	1		1	1
Acetonitrile	1		1	1
Tetrahydrofuran	2		4	1
Toluene	1		4	1
MEK	1		1	1
Organic Acids - Dilute	1		1	1
Non Organic Acids - Dilute	1		1	1
Bases - Dilute	1		1	1
Saline	1		1	1
Bleach 12%	2		1	1
Sodium Hydroxide 20%	1		1	1

Compatibility Legend

1. EXCELLENT
Minimal or no effect
2. GOOD
Possible swelling and or loss of physical properties
3. DOUBTFUL
Moderate or severe swelling and loss of physical properties
4. NOT RECOMMENDED
Severe effect and should not be considered

*The above is an Abbreviated Chemical Compatibility Chart. Please consult factory for additional information.

Regulatory

EMC Directive:

IEC61000-4-2: 2008-12 ESD - Criterion A
IEC61000-4-3: 2010-04 Radiated Susceptibility - Criterion A
CISPR11: 2010-05 Radio Frequency Emission - Class B

Low Voltage Directive

IEC61010-1: 3rd 2010-06 Sec. 10.1 Surface temperature limits for protection against burns

RoHS Directive (2002/95/EC)

REACH EC 1907/2006

R9 Miniature Diaphragm Isolation Valve

Typical Flow Diagram

9 mm on Center Dispense Application

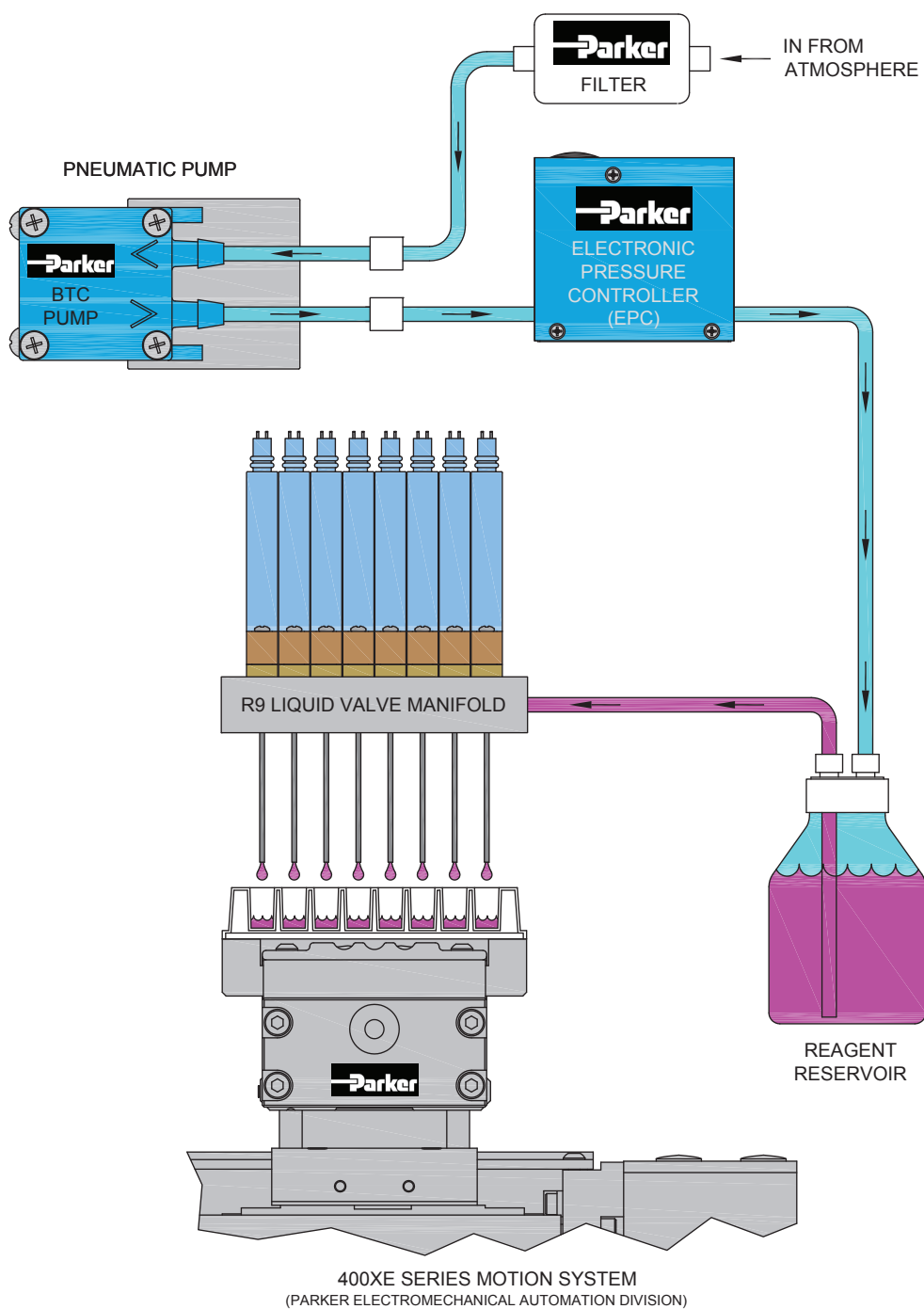

R9 Miniature Diaphragm Isolation Valve

Typical Flow Diagram

Probe Wash Station

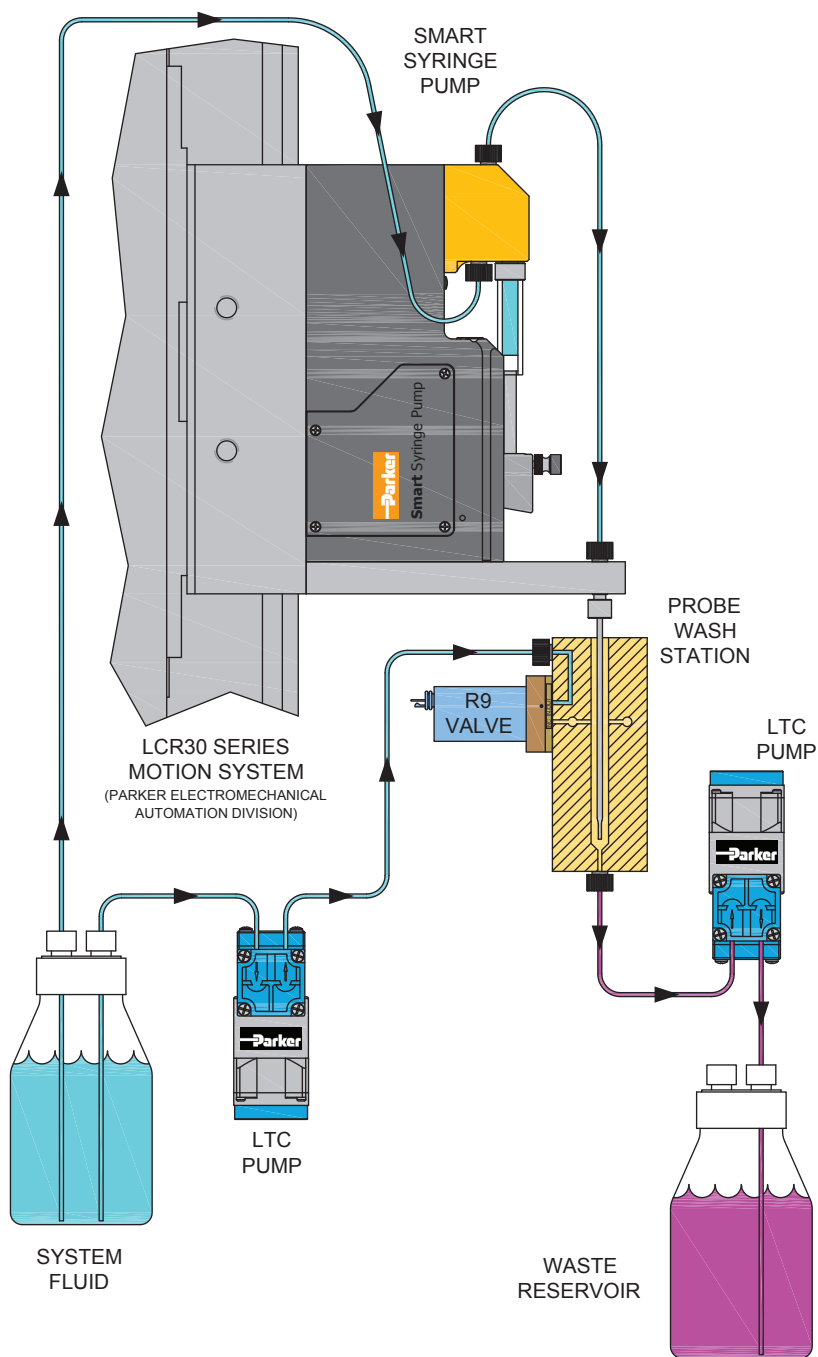

R9 Miniature Diaphragm Isolation Valve

Ordering Information

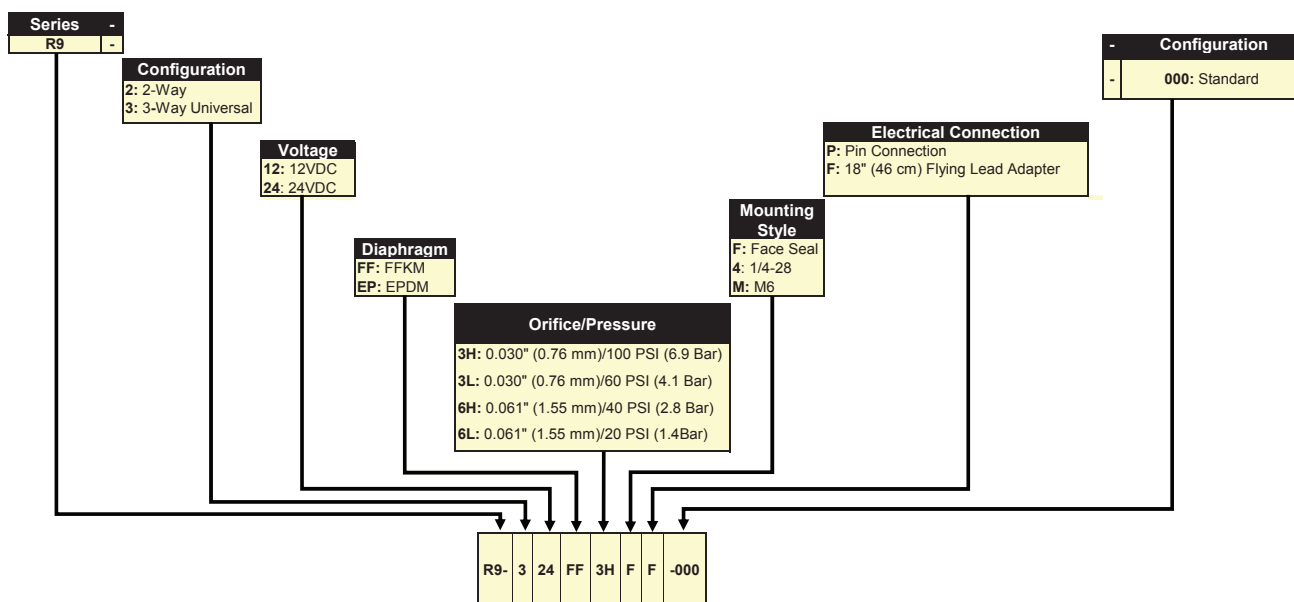

Example Part Number Three way, 24 Volt, FFKM Diaphragm/seals, 0.030" (0.76 MM) orifice, 100PSI (6.9 Bar) Max Pressure, Face Seal, 18"(46 cm) flying lead adapter. (Screws sold separately)

Accessories	
Part Number	Description
R9-0003-016	1/4 - 28 Female Threaded Sub Base Manifold, 2-Way
R9-0001-016	1/4 - 28 Female Threaded Sub Base Manifold, 3-Way
R9-0004-016	M6 Female Threaded Sub Base Manifold, 2-Way
R9-0002-016	M6 Female Threaded Sub Base Manifold, 3-Way
LQX-0001-290-001	18" (46 cm) Flying Lead Adapter
M2-0004-630-PNPH	Mounting Screw, SST 18-8, Metric, 16 MM LG (2 Required)
002-0056-625PNPH	Mounting Screw, SST 18-8, 2-56, 5/8" LG (2 Required)
R9-0001-300	FFKM O-Ring
R9-0002-300	EPDM O-Ring

NOTE: In order to provide the best possible solution for your application, please provide the following requirements when contacting Applications Engineering:

- Media, Inlet & Outlet Pressures
- Minimum Required Flow Rate
- System Supply Voltage
- Media and Media Temperature Range
- Ambient Temperature Range

Please click on the Order On-line button (or go to www.parker.com/precisionfluidics/R9) to configure your R9 Miniature Diaphragm Isolation Valve. For more detailed information, visit us on the Web, or call 603-595-1500.

For more information call +1 603 595 1500 or email ppinfo@parker.com
Visit www.parker.com/precisionfluidics



C7 Valve Miniature Cartridge Liquid Valve

7 mm Miniature Liquid Cartridge Valve



The Series C7 is a miniature cartridge style solenoid valve with a compact 7 mm diameter. This unique design combines small size, light weight and low power consumption with high flow repeatability and fast response time over an exceptionally long life, up to 130 million cycles. Available in 2-way configurations, the valve is manifold mounted utilizing a simple securing system reducing assembly time.

Markets

- Analytical Chemistry
- Clinical Diagnostics
- Environmental Monitoring
- Print

Applications

- Reagent Addition
- Wash
- Waste
- Flow Control
- Large format Inkjet systems

Features

- Variety of orifice sizes with pressures up to 145 PSI (10 bar).
- Floating frictionless plunger enables reliable and repeatable operation up to 130 Million cycles.
- Low power design reduces heat and energy consumption.
- Cartridge configuration enables compact integration saving space and weight.
- Simple mechanical fastening prevents valve being dislodged due to vibration or pressure spikes.
- RoHS & REACH compliant. 

Product Specifications

Mechanical

Valve Type:
Solenoid Cartridge Valve 2-Way Normally Closed (NC)
Media: Gases* and Liquids (see the details in gas datasheet)
Operating Environment:
32°F to 122°F (0°C to 50°C)
Storage Environment:
-40°F to 158°F (-40°C to 70°C)
Dimensions:
- Diameter: 0.28 in (7 mm) - Length: 0.79 in (20 mm)
Porting:
Cartridge Seal
Weight:
0.11 oz (3.1 g)
Internal Volume:
2-Way: 81µL

Orifice	0.012 in (0.3 mm)	0.020 in (0.5 mm)	0.031 in (0.8 mm)	0.039 in (1.0 mm)
Type	2-Way	2-Way	2-Way	2-Way
Max Vacuum & Pressure	PSI	145	116	73
	Bar	10	8	6
	SCCM (water)	146	260	429

Electrical

Voltage (VDC):
12 and 24 VDC ± 5% (Other voltages available on request.)
Electrical Connections:
3.2" (80 mm) Flying Leads [28 AWG]
Power:
Typical 0.5W - 1.2W (Please see Table 1 for more details)
Wetted Materials
Body:
Stainless Steel Series 300 and 400
Seals: (Internal and External)
FKM, EPDM

Performance Characteristics

Response:
10 ms Maximum, Cycling
Recommended Filtration:
0.3 mm Orifice 5 µm
0.5 mm, 0.8 mm, & 1.0 mm Orifice 10 µm
Reliability:
2-Way: 130 Million Cycles
0.90 Reliability Factor
95% Confidence

C7 Miniature Liquid Cartridge Valve

Flow Curve

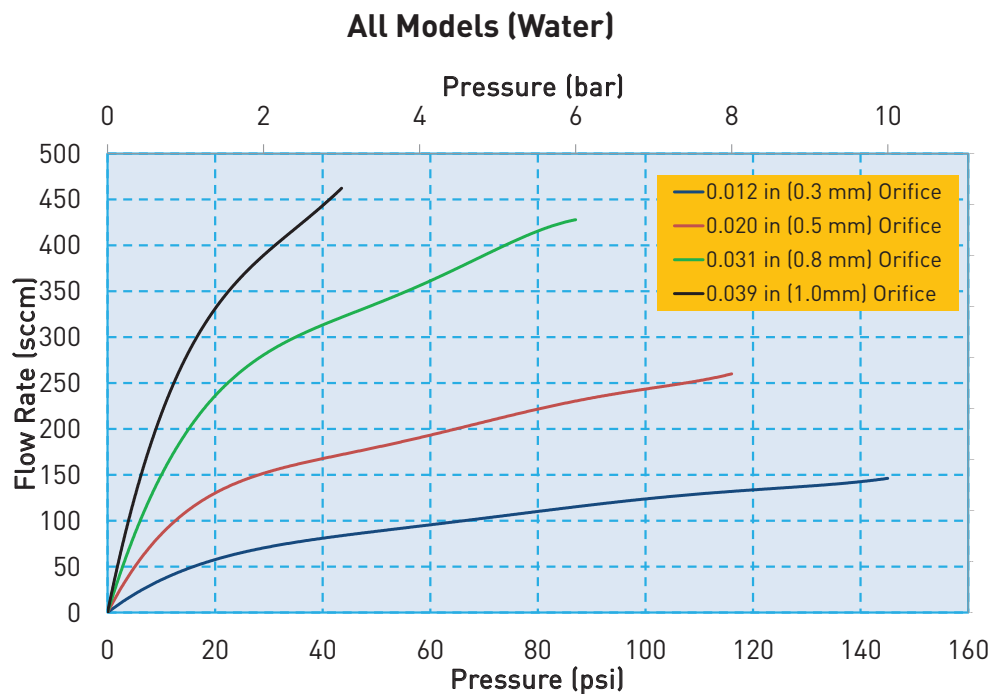

Flow Curve

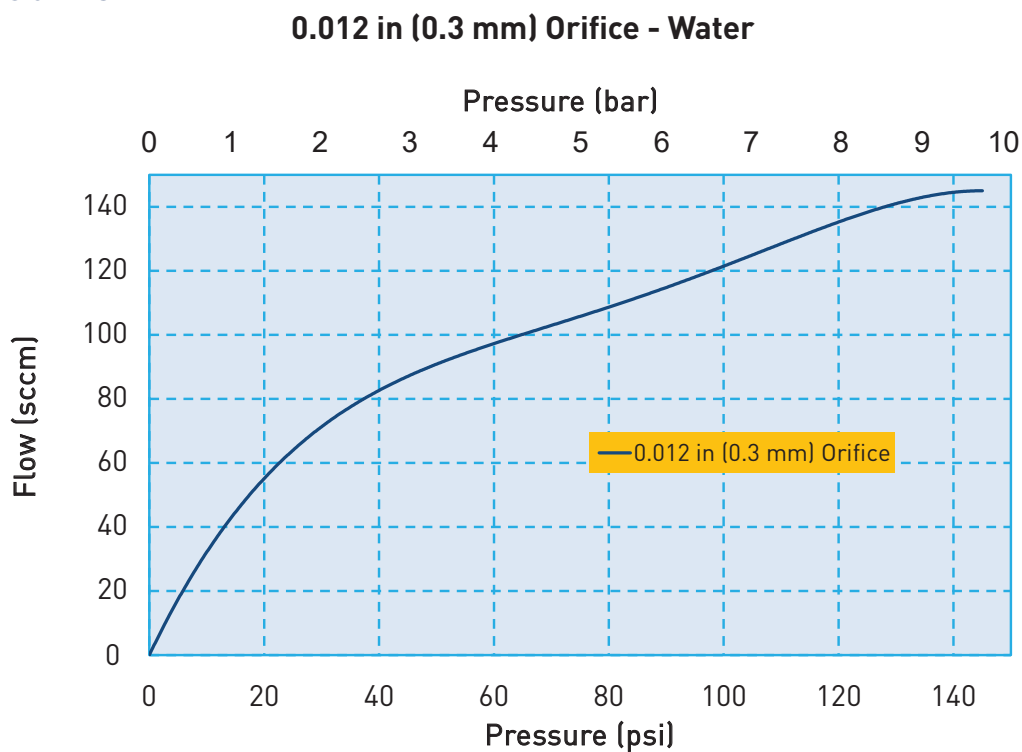

C7 Miniature Liquid Cartridge Valve

Flow Curve

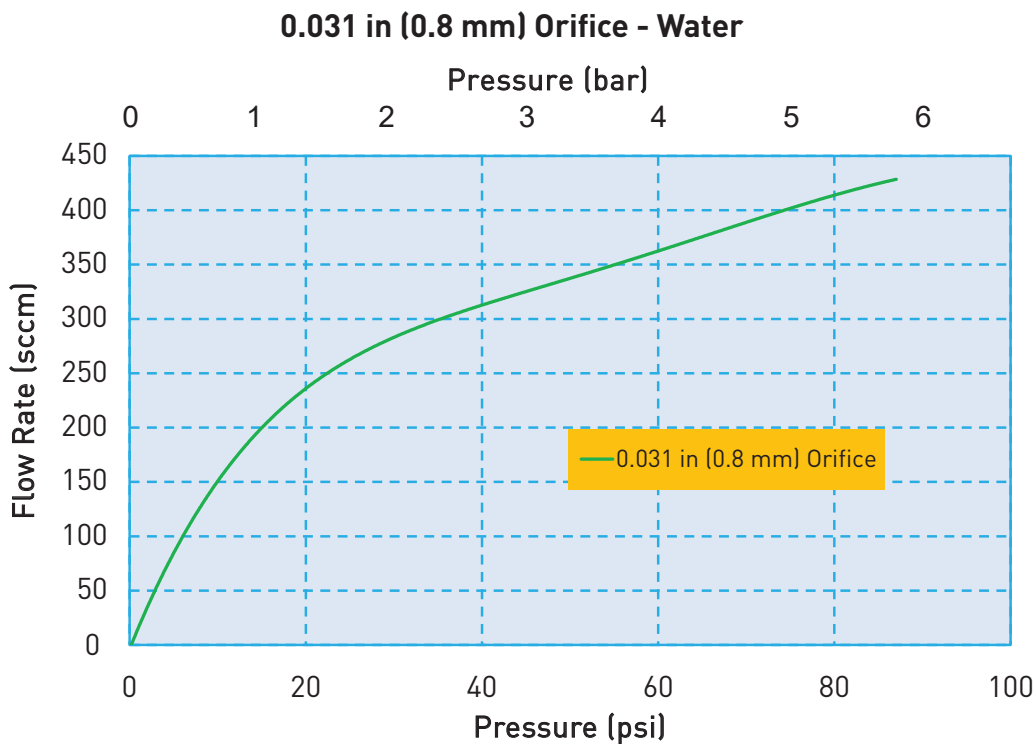
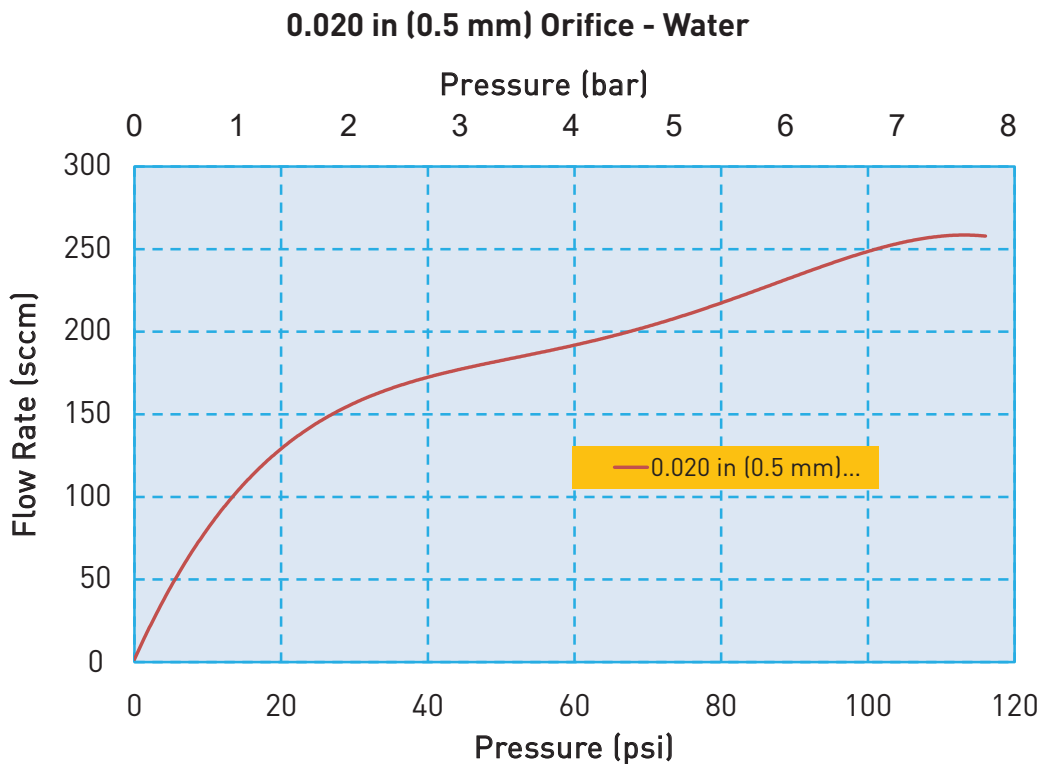

C7 Miniature Liquid Cartridge Valve

Flow Curve

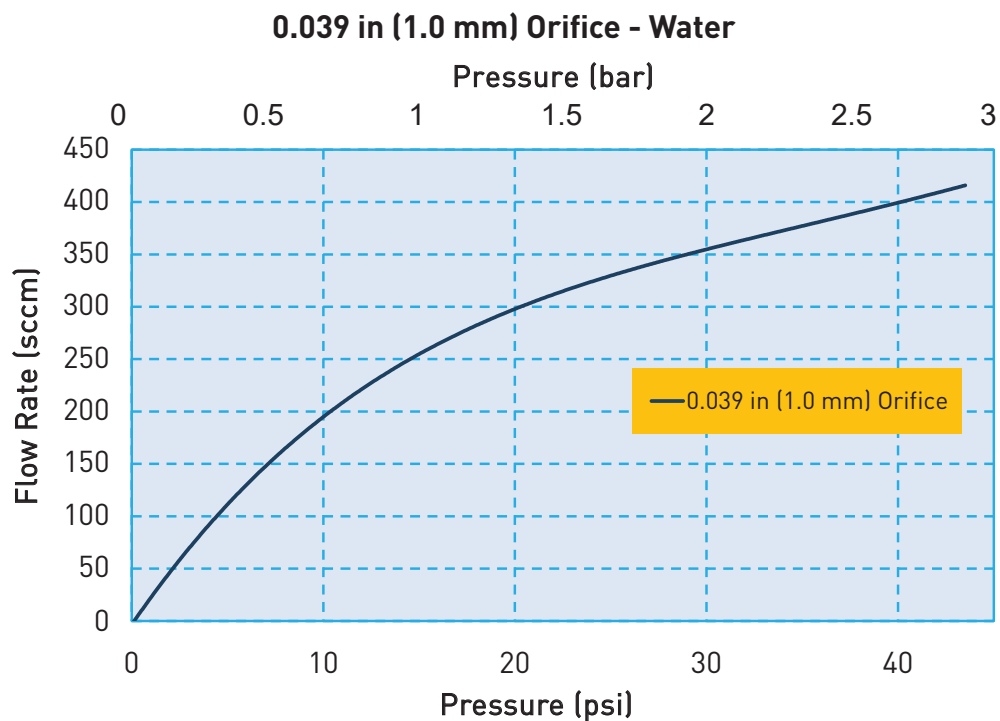

Electrical Interface



Wire Leads

Standard: 3.2 in (80 mm) Wire Leads, stripped at end

C7 Miniature Liquid Cartridge Valve

Electrical Requirements

Table 1

Orifice	0.012 in (0.3 mm)		0.020 in (0.5 mm)		0.031 in (0.8 mm)		0.039 in (1.0 mm)	
Valve Type	2-Way		2-Way		2-Way		2-Way	
Voltage (VDC)*	12	24	12	24	12	24	12	24
Power (Watts)	0.5	0.6	1	0.85	1	1.2	1	1.2
Resistance [Ohm]**	288	995	140	700	140	495	140	495
* $\pm 5\%$, other voltages available on request								
** $\pm 5\%$ @ 68°F, 20°C								

Liquid Interface/Mechanical Integration

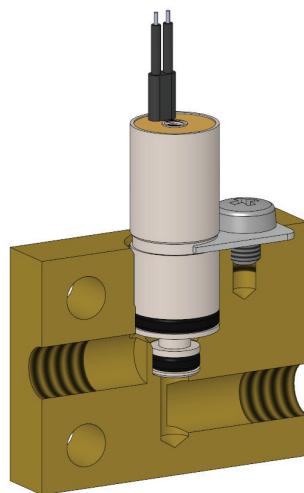

C7 Miniature Liquid Cartridge Valve

Dimensions

2-Way Valve Configuration

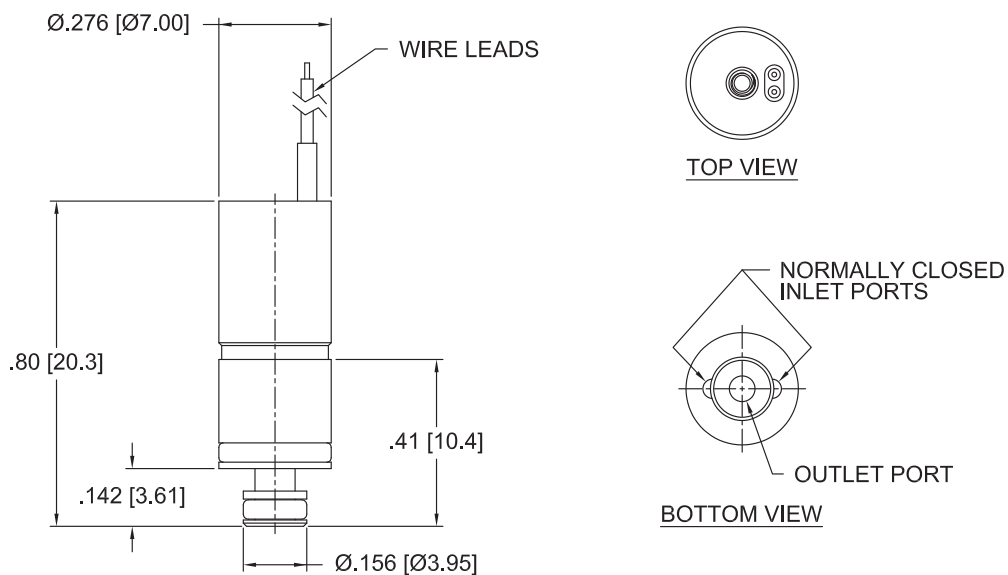

UNITS
IN [MM]

ANSI Symbols

2-Way Normally Closed

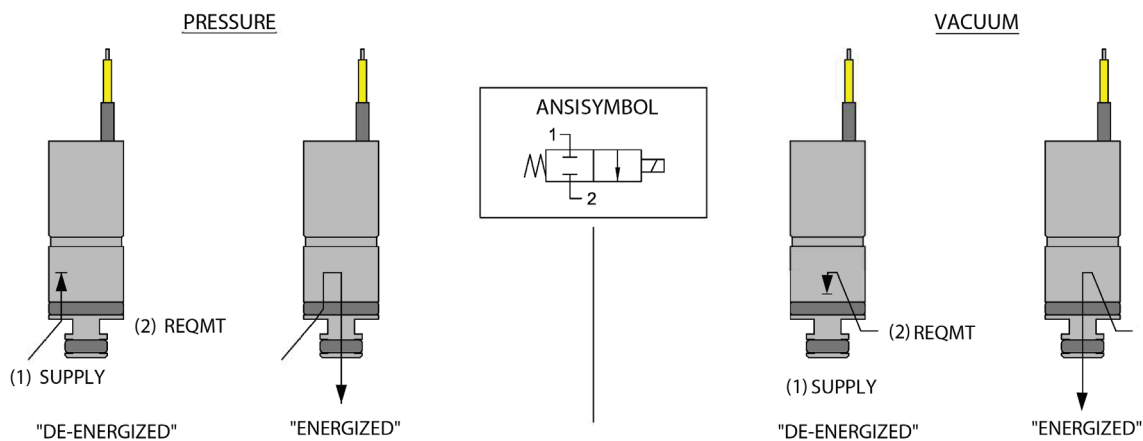

C7 Miniature Liquid Cartridge Valve

Installation and Use

During installation of the C7 valve, the maximum force allowed to press it into the manifold is: 6.74 lbf (30 N)
 Lubrication is recommended (I.E. alcohol or DI water depending on compatibility constraints)

Recommended Valve Manifold Dimensions

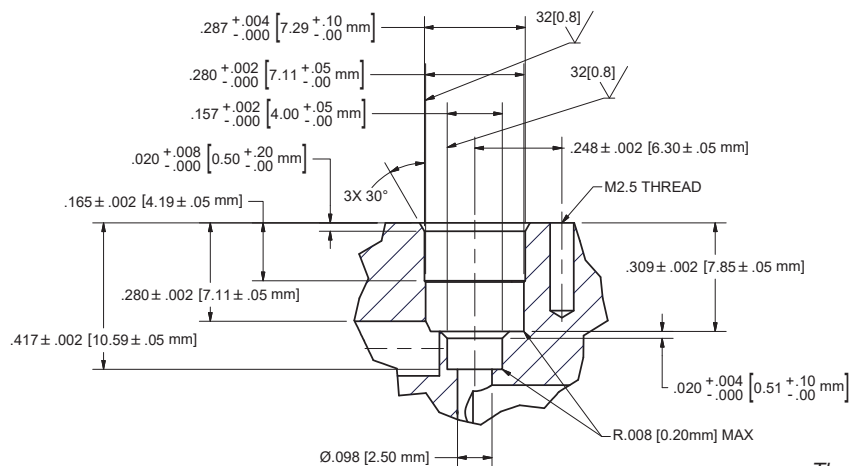

Recommended Valve Mounting

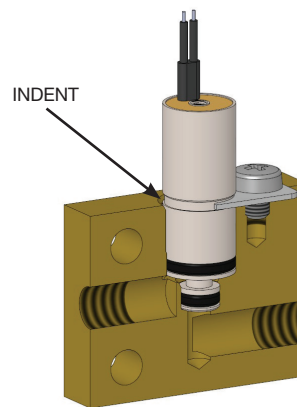

The correct location to use when holding the valve in place in the manifold is the indent at the middle of the valve body. If the top of the valve is used to hold the valve in place, the working pressure the valve will see, can push the valve upward and exceed the maximum insertion force for the valve. This could damage the valve.

Installation and Use

C7 Evaluation Manifold Dimensions and Design C07-MCS

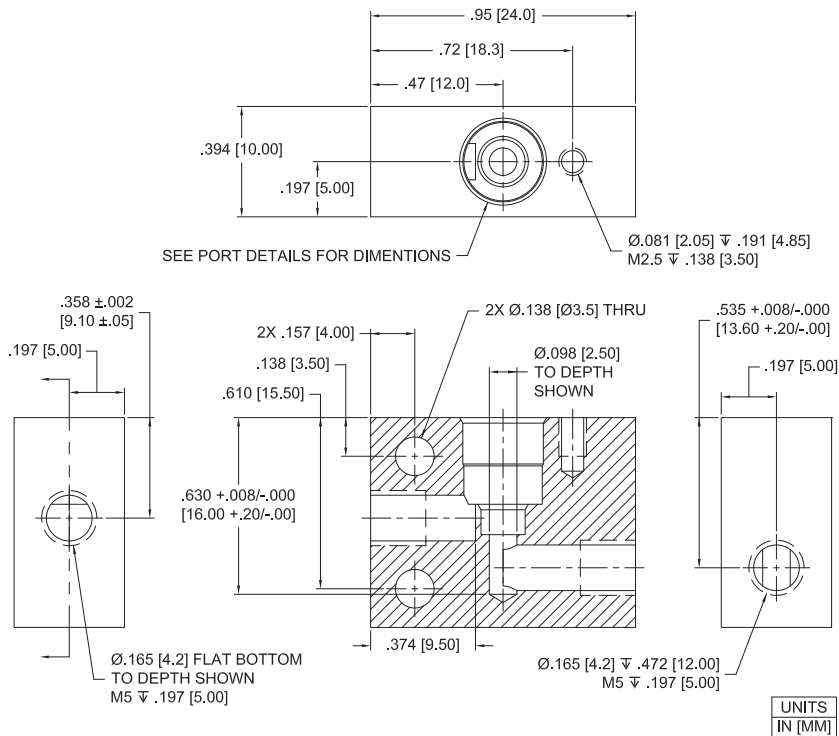

C7 Miniature Liquid Cartridge Valve

Installation and Use

Optional Reduced Power Control Method

“Hit and Hold” is an optional control method to increase power efficiency for the C7 series valves.

Hit and Hold is a common control method used to reduce component power consumption and heat generation without sacrificing performance. The “Hit” or “Spike” state refers to the rated voltage required to actuate the valve. The “Hold” state is a substantial reduction in the rated voltage (normally 50% of the rated voltage) that maintains the valve in an actuated state.

Hit and Hold control can be incorporated using several different approaches, including discrete component circuits or programmable logic. The graph below illustrates a voltage “Hit” and “Hold” control method, however pulse width modulation (PWM) is also an acceptable control method.

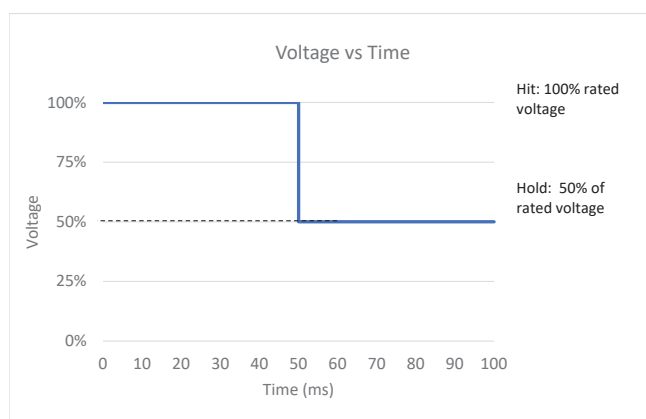

C7 Hit and Hold Specification	
Hit Voltage Level	Rated Voltage
Hold Voltage Level	50% of Rated Voltage
Minimum Hit Time	50 ms
Maximum Hit Time	N/A
PWM Frequency (Minimum)	1 kHz
Hold Nominal Duty Cycle	50%

This method greatly reduces power consumption because the valve only draws full current for a short period of time making it ideal for applications with sensitive power budgets.

Note: 50% duty cycle is a general recommendation; therefore, it is recommended that specific application testing is completed to verify the proper “hold” requirement. Factors that could impact hit and hold voltage levels include vibration, shock, pressure variation and pressure locations that are driven from specific usage. The hit and hold circuit design, combined with Parker’s valve, need to be validated for each specific application to ensure the valve will actuate under all usage conditions. **Contact Factory for more details.**

C7 Miniature Liquid Cartridge Valve

Chemical Compatibility Chart*

Chemical	Seal Options			Other Wetted Materials
	FFKM	FKM	EPDM	Stainless Steel
DI Water	1	1	1	1
Methanol	1	4	1	2
Isopropanol	1	1	1	1
Ethanol	1	3	1	1
Acetonitrile	1	4	1	
Tetrahydrofuran	1	4	4	
Toluene	1	2	4	1
MEK	4	1	1	3
Organic Acids - Dilute	1	1	1	4
Non Organic Acids - Dilute	1	1	1	2
Bases - Dilute	1	1	1	1
Saline	1	1	1	2
Bleach 12%	2	1	1	4
Sodium Hydroxide 20%	1	2	1	2

*The above is an Abbreviated Chemical Compatibility Chart. Please consult factory for additional information.

Compatibility Legend

1. EXCELLENT
Minimal or no effect
2. GOOD
Possible swelling and or loss of physical properties
3. DOUBTFUL
Moderate or severe swelling and loss of physical properties
4. NOT RECOMMENDED
Severe effect and should not be considered

Accessories

C7 Evaluation Manifold with clip and screw (Valve not included)

C07-MCS



Replacement Clip for C07-MCS

C07-C



Replacement Screw for C07-MCS

C07-S



Replacement O-Ring for C7 Valve, Large

C07-LG (FKM)
C07-LGE (EPDM)



Replacement FKM O-Ring for C7 Valve, Small

C07-SM (FKM)
C07-SME (EPDM)



C7 Miniature Liquid Cartridge Valve

Ordering Information

Sample Part ID	C07	-	2	24	FK	03	F	F	-	000
Description	Series		Configuration	Coil Voltage	Elastomer	Orifice	Mounting Style	Electrical Interface		Custom
Options	C07: 7 mm Cartridge Valve		2: 2-Way	12: 12 VDC 24: 24 VDC	EP: EPDM FK: FKM	03: 0.012 in (0.3 mm) 05: 0.020 in (0.5 mm) 08: 0.031 in (0.8 mm) 10: 0.039 in (1.0 mm)	F: Face Seal	F: 3.2 in (80 mm) flying lead		000: Standard

Accessories

C07-MCS: C07 Evaluation Manifold with Clip and Screw, Not supplied with the valve.

C07-C: Replacement Clip used on C07-MCS*

C07-S: Replacement Screw used on C07-MCS*

C07-LG: Spare O-Ring for C07 Valve, FKM, Large**

C07-LGE: Spare O-Ring for C07 Valve, EPDM, Large**

C07-SM: Spare O-Ring for C07 Valve, FKM, Small**

C07-SME: Spare O-Ring for C07 Valve, EPDM, Small**

* Not Supplied with Valve, Replacement Part for C07-MCS ** Supplied with Valve

NOTE: For Evaluation - Please Add C07-MCS To Your Sample Order. All Valves Ship With O-Rings Installed

NOTE: In order to provide the best possible solution for your application, please provide the following requirements when contacting Applications Engineering:

- Media, Inlet & Outlet Pressures
- Minimum Required Flow Rate
- System Supply Voltage
- Media & Ambient Temperature Range



Please click on the Order On-line button to configure your C7 valve. For CAD models and more detailed information, please visit us on the Web (www.parker.com/precisionfluidics/C7_LiquidCartridgeValve), call (+1.603.595.1500) or email at ppfinfo@parker.com.

Parker Hannifin Precision Fluidics Division reserves the right to make changes. Drawings are for reference only.

For more information call +1 603 595 1500 or email ppfinfo@parker.com
Visit www.parker.com/precisionfluidics



C15 Valve

Miniature Cartridge Liquid Valve

15 mm Miniature Liquid Cartridge Valve



The Series C15 is a miniature cartridge style solenoid valve with a unique design that combines small size, light weight and low power consumption with high flow repeatability and fast response time over an exceptionally long life, up to 500 million cycles. Available in a 2-way configuration, the valve is manifold mounted utilizing a simple securing system reducing assembly time.

Markets

- Analytical Chemistry
- Clinical Diagnostics
- Environmental Monitoring
- Print

Applications

- Reagent Addition
- Wash
- Waste
- Flow Control
- Large format Inkjet systems

Features

- Variety of orifice sizes with pressures up to 145 PSI (10 bar).
- Floating frictionless plunger enables reliable and repeatable operation up to 500 Million cycles.
- Low power design reduces heat and energy consumption.
- Cartridge configuration enables compact integration saving space and weight.
- Simple mechanical fastening prevents valve being dislodged due to vibration or pressure spikes.
- RoHS & REACH compliant.



Product Specifications

Mechanical

Valve Type:
Solenoid Cartridge Valve
2-Way Normally Closed (NC)
Media: Gases* and Liquids
(see the details in gas datasheet)
Operating Environment:
32°F to 122°F (0°C to 50°C)
Storage Environment:
-40°F to 158°F (-40°C to 70°C)
Dimensions:
- Diameter: 0.59 in (15 mm)
- Length: 1.14 in (29 mm)
Porting:
Cartridge Seal
Weight:
0.78 oz (22 g)
Internal Volume:
2-Way: 391 µL

Orifice	0.020 in (0.5 mm)	0.040 in (1.0 mm)	0.060 in (1.5 mm)	0.080 in (2.0 mm)	
Type	2-Way	2-Way	2-Way	2-Way	
Max Vacuum & Pressure	PSI	145	116	58	
	Bar	10	8	4	
	Cv	0.01	0.032	0.058	0.093
	SCCM (water)	400	1160	1670	1640

Electrical

Voltage (VDC):
12 and 24 VDC ± 5%
(Other voltages available on request.)
Electrical Connections:
3.2" (80 mm) Flying Leads [24 AWG]
Power:
Typical 1.1W - 1.7W
(Please see Table 1 for more details)

Wetted Materials

Body:
Stainless Steel Series 300 and 400
Seals: (Internal and External)
FKM, EPDM

Performance Characteristics

Response:
10 ms Maximum, Cycling
Proof Pressure:
120% of Rated Maximum Pressure
Recommended Filtration:
10 µm
Reliability:
2-Way: 500 Million Cycles
0.90 Reliability Factor
95% Confidence

C15 Miniature Liquid Cartridge Valve

Flow Curve

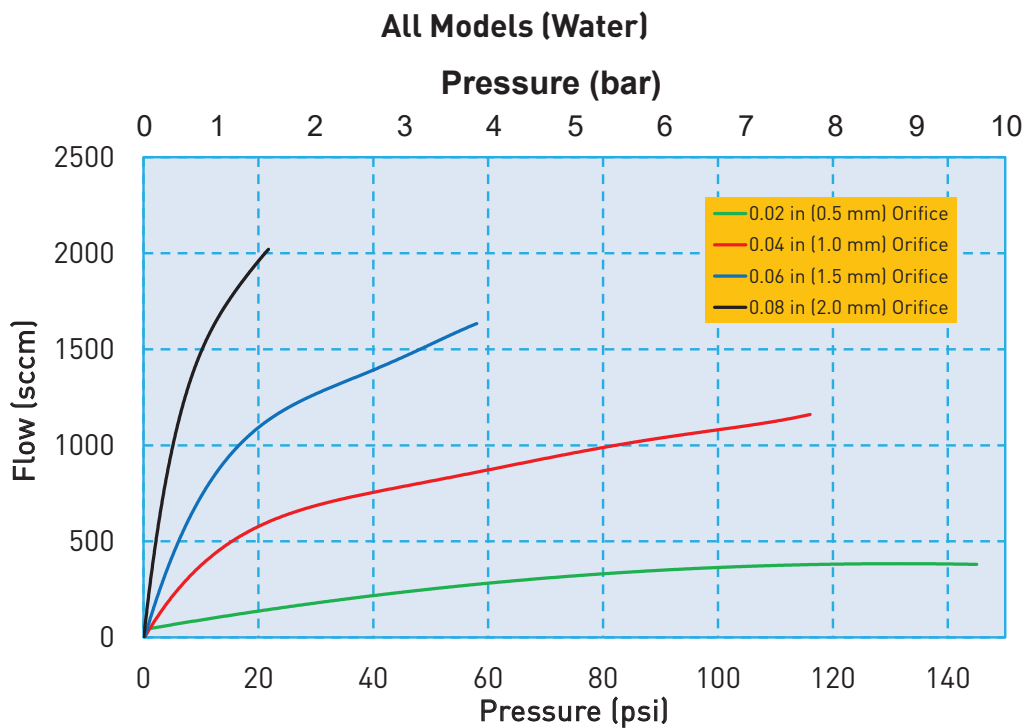

Flow Curve

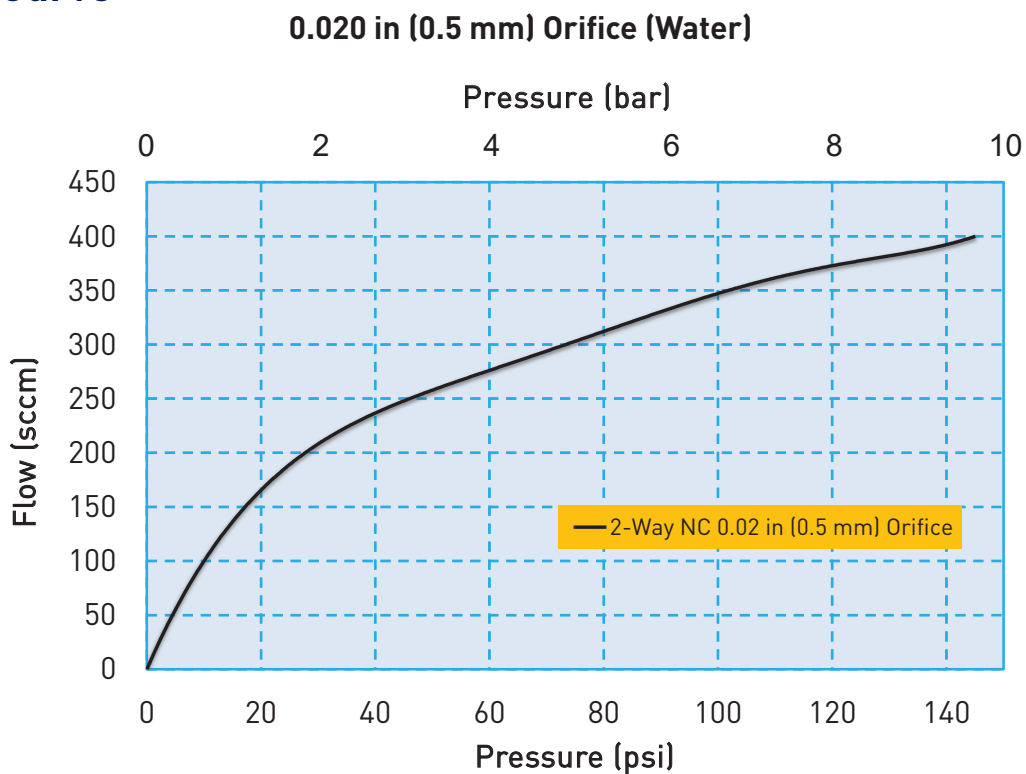

C15 Miniature Liquid Cartridge Valve

Flow Curve

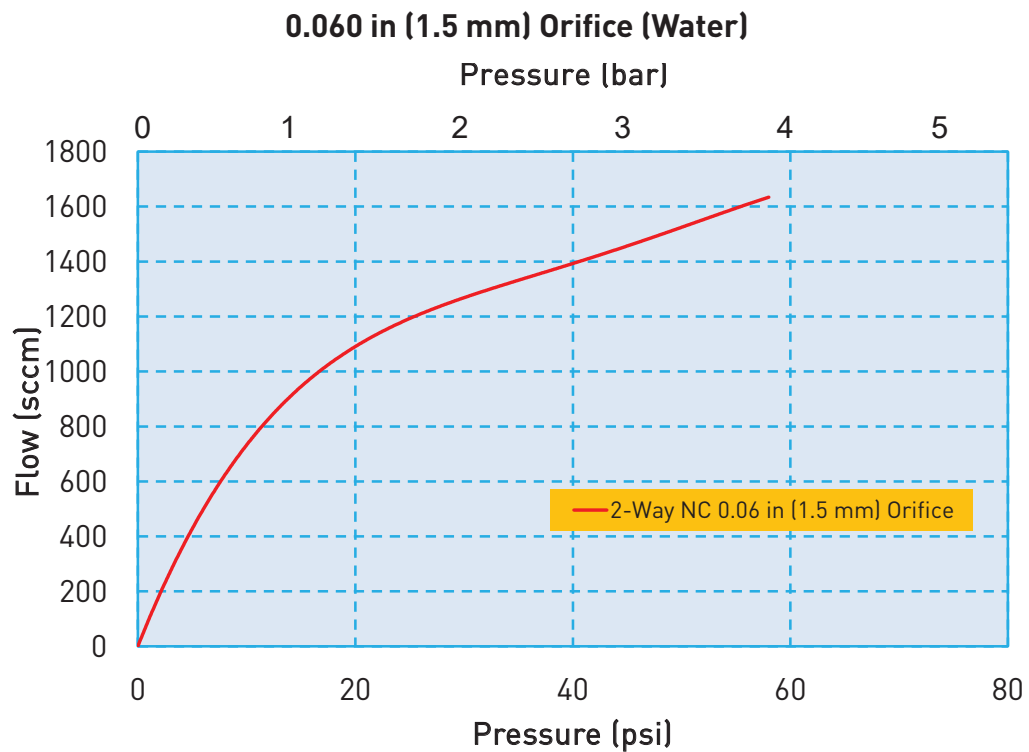
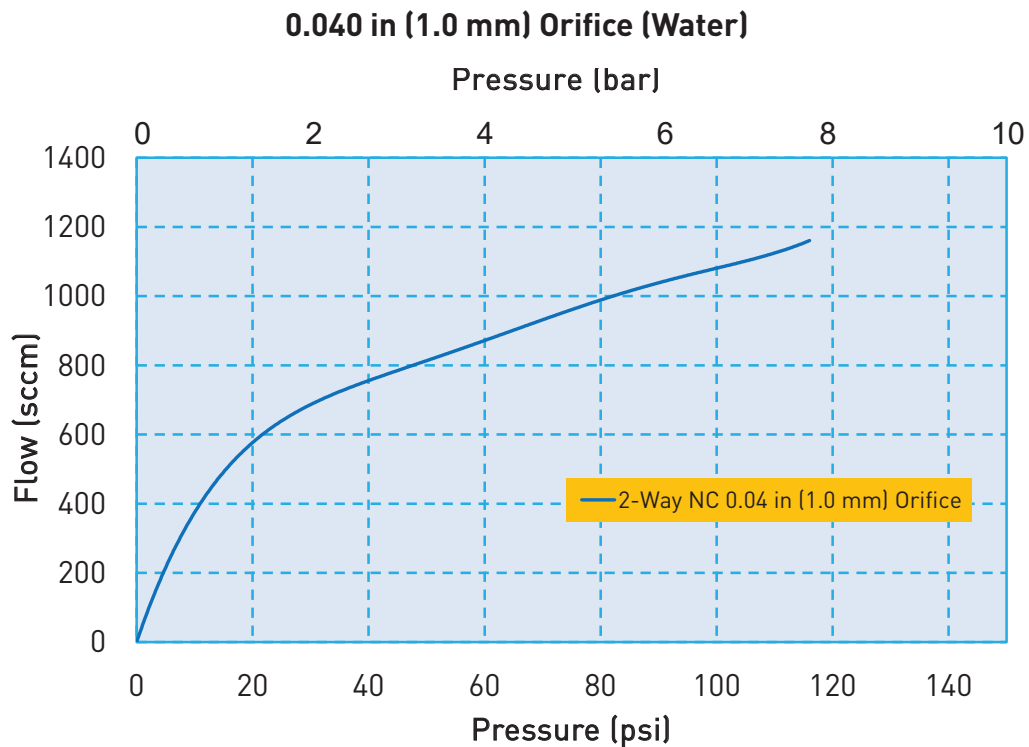

C15 Miniature Liquid Cartridge Valve

Flow Curve

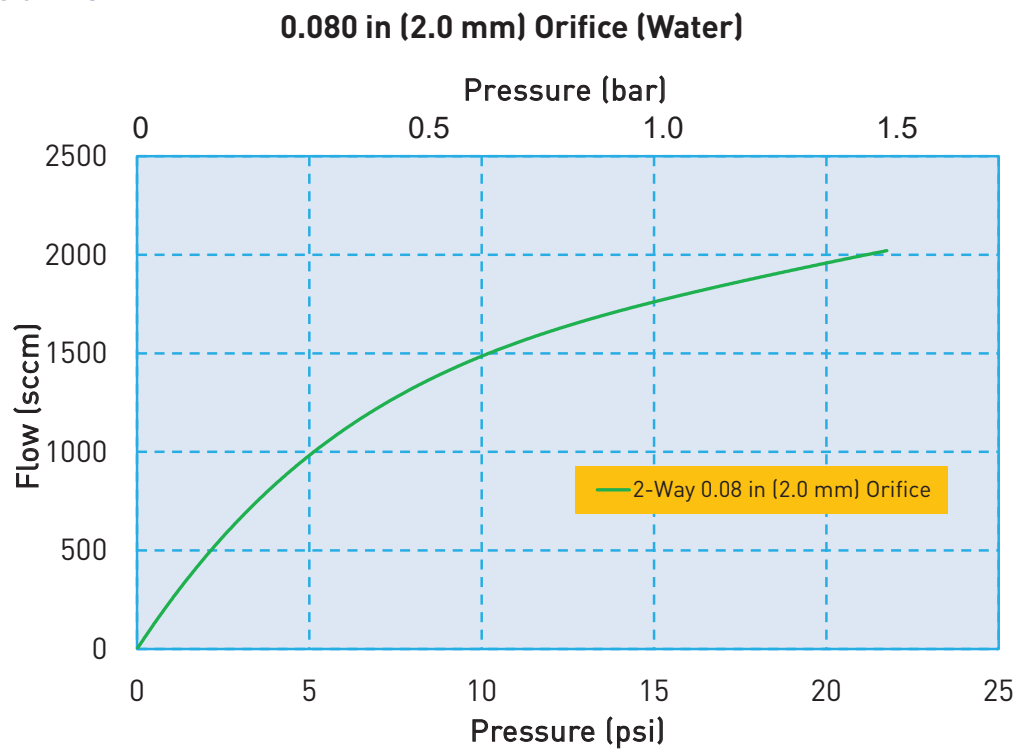

Electrical Interface



Wire Leads

Standard: 3.2 in (80 mm) Wire Leads, stripped at end

C15 Miniature Liquid Cartridge Valve

Electrical Requirements

Table 1

Orifice	0.02 in (0.5 mm)		0.04 in (1.0 mm)		0.06 in (1.5 mm)		0.08 in (2.0 mm)	
Valve Type	2-Way		2-Way		2-Way		2-Way	
Voltage (VDC)*	12	24	12	24	12	24	12	24
Power (Watts)	1.1	1.1	1.7	1.6	1.7	1.6	1.7	1.6
Resistance (Ohm)**	132	525	85	361	85	361	85	361
* $\pm 5\%$, other voltages available on request								
** $\pm 5\%$ @ 68°F, 20°C								

Liquid Interface/Mechanical Integration



C15 Miniature Liquid Cartridge Valve Dimensions

2-Way Valve Configuration

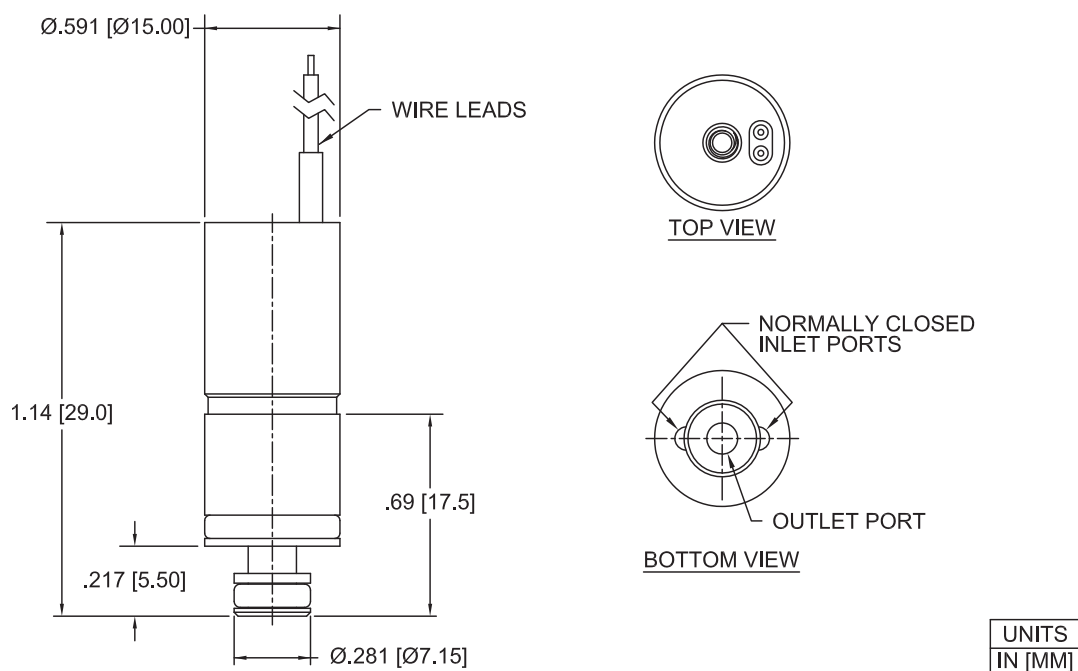

ANSI Symbols

2-Way Normally Closed

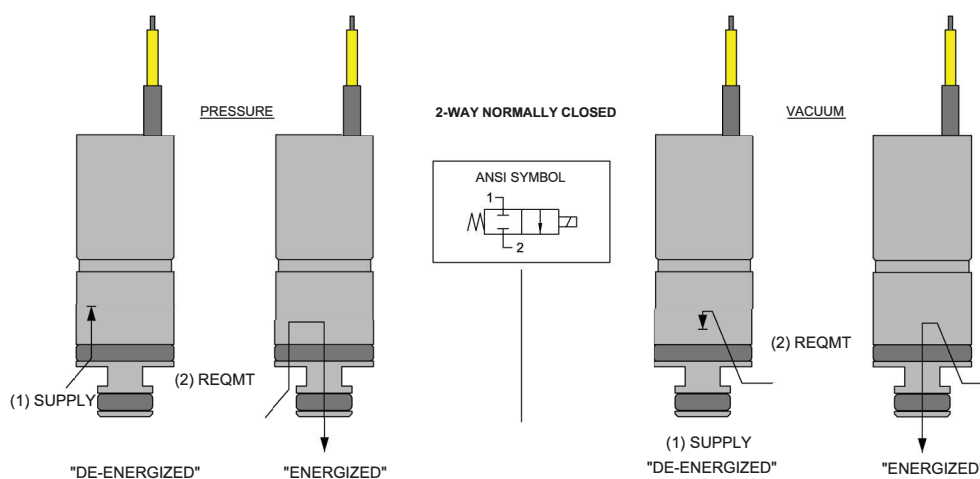

C15 Miniature Liquid Cartridge Valve

Installation and Use

During installation of the C15 valve, the maximum force allowed to press it into the manifold is: 22.48 lbf (100 N)
 Lubrication is recommended (I.E. alcohol or DI water depending on compatibility constraints)

Recommended Valve Manifold Dimensions

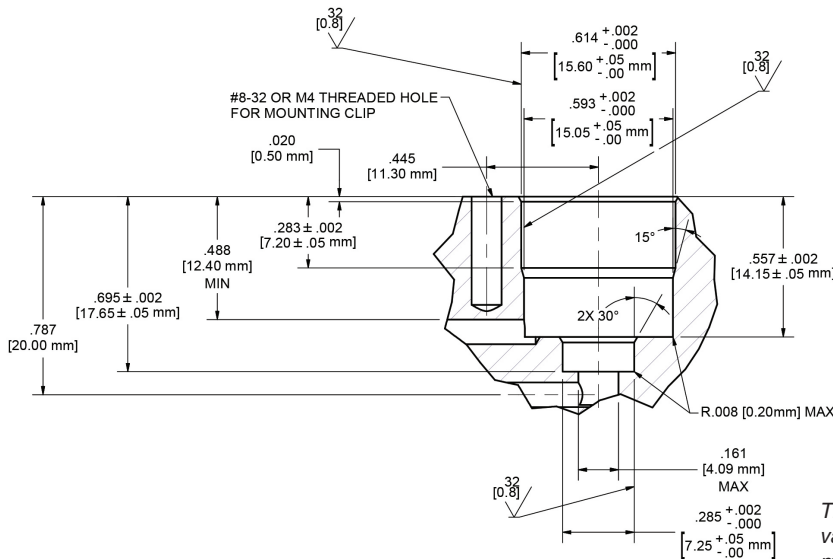

Recommended Valve Mounting

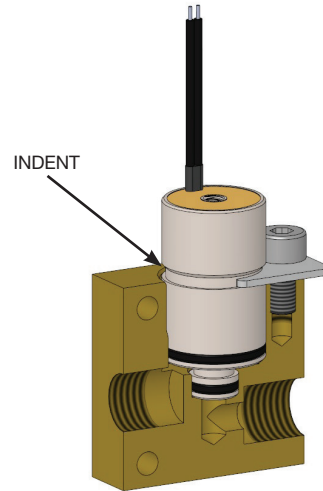

The correct location to use when holding the valve in place in the manifold is the indent at the middle of the valve body. If the top of the valve is used to hold the valve in place, the working pressure the valve will see, can push the valve upward and exceed the maximum insertion force for the valve. This could damage the valve.

Installation and Use

C15 Evaluation Manifold Dimensions and Design C15-MCS

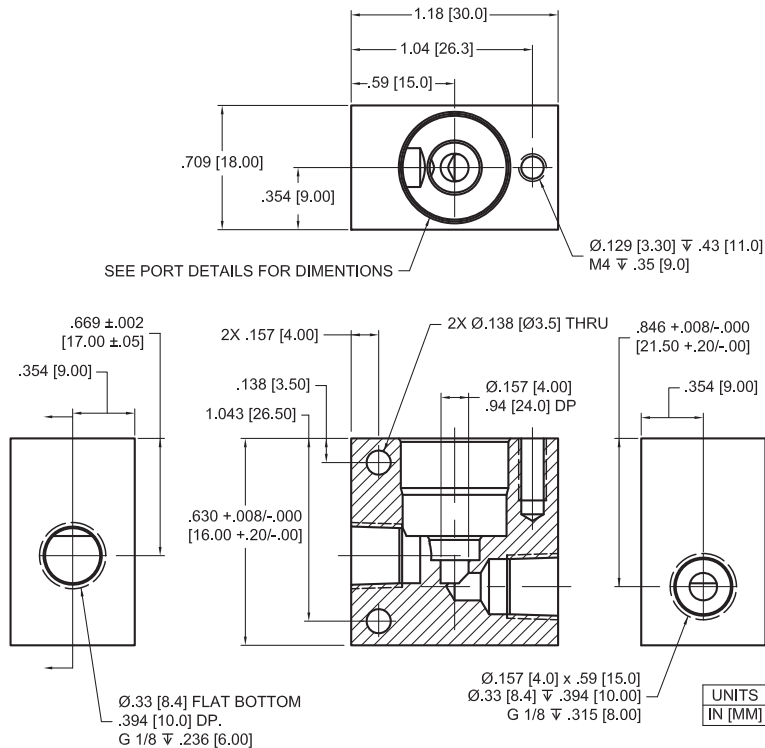

C15 Miniature Liquid Cartridge Valve

Installation and Use

Optional Reduced Power Control Method

“Hit and Hold” is an optional control method to increase power efficiency for the C15 series valves.

Hit and Hold is a common control method used to reduce component power consumption and heat generation without sacrificing performance. The “Hit” or “Spike” state refers to the rated voltage required to actuate the valve. The “Hold” state is a substantial reduction in the rated voltage (normally 50% of the rated voltage) that maintains the valve in an actuated state.

Hit and Hold control can be incorporated using several different approaches, including discrete component circuits or programmable logic. The graph below illustrates a voltage “Hit” and “Hold” control method, however pulse width modulation (PWM) is also an acceptable control method.

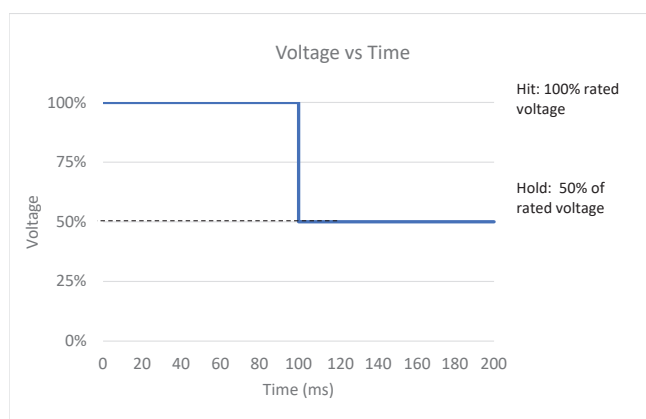

C15 Hit and Hold Specification	
Hit Voltage Level	Rated Voltage
Hold Voltage Level	50% of Rated Voltage
Minimum Hit Time	100 ms
Maximum Hit Time	N/A
PWM Frequency (Minimum)	1 kHz
Hold Nominal Duty Cycle	50%

This method greatly reduces power consumption because the valve only draws full current for a short period of time making it ideal for applications with sensitive power budgets.

Note: 50% duty cycle is a general recommendation; therefore, it is recommended that specific application testing is completed to verify the proper “hold” requirement. Factors that could impact hit and hold voltage levels include vibration, shock, pressure variation and pressure locations that are driven from specific usage. The hit and hold circuit design, combined with Parker’s valve, need to be validated for each specific application to ensure the valve will actuate under all usage conditions. **Contact Factory for more details.**

C15 Miniature Liquid Cartridge Valve Chemical Compatibility Chart*

Chemical	Seal Options			Other Wetted Materials
	FFKM	FKM	EPDM	Stainless Steel
DI Water	1	1	1	1
Methanol	1	4	1	2
Isopropanol	1	1	1	1
Ethanol	1	3	1	1
Acetonitrile	1	4	1	
Tetrahydrofuran	1	4	4	
Toluene	1	2	4	1
MEK	4	1	1	3
Organic Acids - Dilute	1	1	1	4
Non Organic Acids - Dilute	1	1	1	2
Bases - Dilute	1	1	1	1
Saline	1	1	1	2
Bleach 12%	2	1	1	4
Sodium Hydroxide 20%	1	2	1	2

*The above is an Abbreviated Chemical Compatibility Chart. Please consult factory for additional information.

Compatibility Legend

- EXCELLENT**
Minimal or no effect
- GOOD**
Possible swelling and or loss of physical properties
- DOUBTFUL**
Moderate or severe swelling and loss of physical properties
- NOT RECOMMENDED**
Severe effect and should not be considered

Accessories

C15 Evaluation Manifold with clip and screw (Valve not included)

C15-MCS



Replacement Clip for C15-MCS

C15-C



Replacement Screw for C15-MCS

C15-S



Replacement O-Ring for C15 Valve, Large

C15-LG (FKM)
C15-LGE (EPDM)



Replacement FKM O-Ring for C15 Valve, Small

C15-SM (FKM)
C15-SME (EPDM)



C15 Miniature Liquid Cartridge Valve

Ordering Information

Sample Part ID	C15	-	2	24	FK	05	F	F	-	000
Description	Series	Configuration	Coil Voltage	Elastomer	Orifice	Mounting Style	Electrical Interface	Custom		
Options	C15: 15 mm Cartridge Valve	2: 2-Way	12: 12 VDC 24: 24 VDC	EP: EPDM FK: FKM	05: 0.020 in (0.5 mm) 10: 0.040 in (1.0 mm) 15: 0.060 in (1.5 mm) 20: 0.080 in (2.0 mm)	F: Face Seal	F: 3.2 in (80 mm) flying lead	000: Standard		
Accessories										
<p>C15-MCS: C15 Evaluation Manifold with Clip and Screw, Not supplied with the valve.</p> <p>C15-C: Replacement Clip used on C15-MCS*</p> <p>C15-S: Replacement Screw used on C15-MCS*</p> <p>C15-LG: Spare O-Ring for C15 Valve, FKM, Large**</p> <p>C15-LGE: Spare O-Ring for C15 Valve, EPDM, Large**</p> <p>C15-SM: Spare O-Ring for C15 Valve, FKM, Small**</p> <p>C15-SME: Spare O-Ring for C15 Valve, EPDM, Small**</p> <p style="text-align: center;">* Not Supplied with Valve, Replacement Part for C15-MCS ** Supplied with Valve</p>										

NOTE: For Evaluation - Please Add C15-MCS To Your Sample Order. All Valves Ship With O-Rings Installed

NOTE: In order to provide the best possible solution for your application, please provide the following requirements when contacting Applications Engineering:

- Media, Inlet & Outlet Pressures
- Minimum Required Flow Rate
- System Supply Voltage
- Media & Ambient Temperature Range



Please click on the Order On-line button to configure your C15 valve. For CAD models and more detailed information, please visit us on the Web (www.parker.com/precisionfluidics/C15_LiquidCartridgeValve), call (+1.603.595.1500) or email at ppfinfo@parker.com.

Parker Hannifin Precision Fluidics Division reserves the right to make changes. Drawings are for reference only.

For more information call +1 603 595 1500 or email ppfinfo@parker.com
Visit www.parker.com/precisionfluidics



C21 Valve

Miniature Cartridge Liquid Valve

21 mm Miniature Liquid Cartridge Valve



The Series C21 is a miniature cartridge style solenoid valve with a compact 21 mm diameter. This unique design combines compact size, light weight and low power consumption with high flow repeatability and fast response time over an exceptionally long life up to 20 million cycles. Available in 2-way configuration, the valve is manifold mounted utilizing a simple securing system reducing assembly time.

Markets

- Analytical Chemistry
- Clinical Diagnostics
- Agent Detection
- Print

Applications

- Large format Inkjet systems
- Reagent Addition
- Wash
- Waste
- Flow Control

Features

- Variety of orifice sizes with pressures up to 145 PSI (10 bar).
- Floating frictionless plunger enables reliable and repeatable operation up to 20 Million cycles.
- Low power design reduces heat and energy consumption.
- Compact reduces space and weight.
- 100% calibrated ensuring minimal valve to valve variation.
- RoHS & REACH compliant. 

Product Specifications

Mechanical

Valve Type:
Solenoid Cartridge Valve
2-Way Normally Closed (NC)
Media: Gases* and Liquids (see the details in gas datasheet)
Operating Environment:
32°F to 122°F (0°C to 50°C)
Storage Environment:
-40°F to 158°F (-40°C to 70°C)
Dimensions:
- Diameter: 0.83 in (21 mm)
- Length: 1.54 in (39 mm)
Porting:
Cartridge Seal
Weight:
2.17 oz (60 g)
Internal Volume:
2-Way: 1173µL

Orifice	0.040 in (1.0 mm)	0.080 in (2.0 mm)	0.12 in (3.0 mm)	0.16 in (4.0 mm)
Type	2-Way	2-Way	2-Way	2-Way
Max Vacuum & Pressure	PSI	145	116	58
	Bar	10	8	4
	Cv	0.03	0.08	0.13
	SCCM (water)	1480	3350	3770

Electrical

Voltage (VDC):
12 and 24 VDC ± 5%
(Other voltages available on request.)
Electrical Connections:
3.2" (80 mm) Flying Leads [24 AWG]
Power:
Typical 2.5W - 2.6W
(Please see Table 1 for more details)

Wetted Materials

Body:
Stainless Steel
Seals: (Internal and External)
FKM, EPDM

Performance Characteristics

Response:
10 ms Maximum, Cycling
Recommended Filtration:
10 µm
Reliability:
2-Way: 20 Million Cycles
0.90 Reliability Factor
95% Confidence

C21 Miniature Liquid Cartridge Valve

Flow Curve

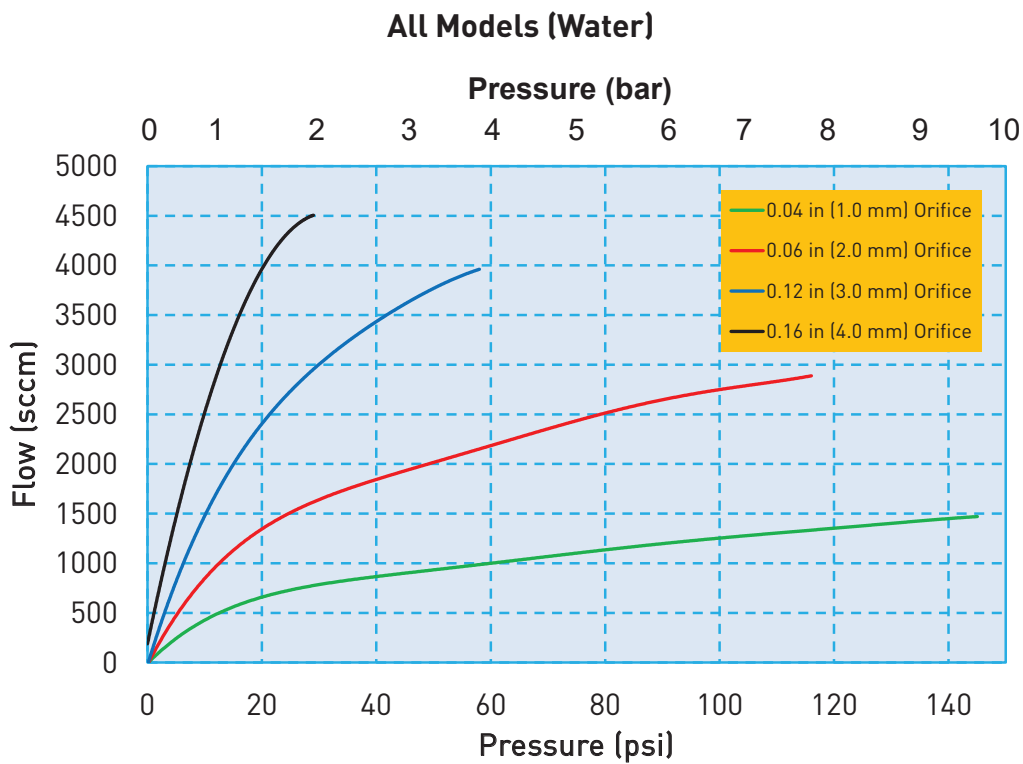

Flow Curve

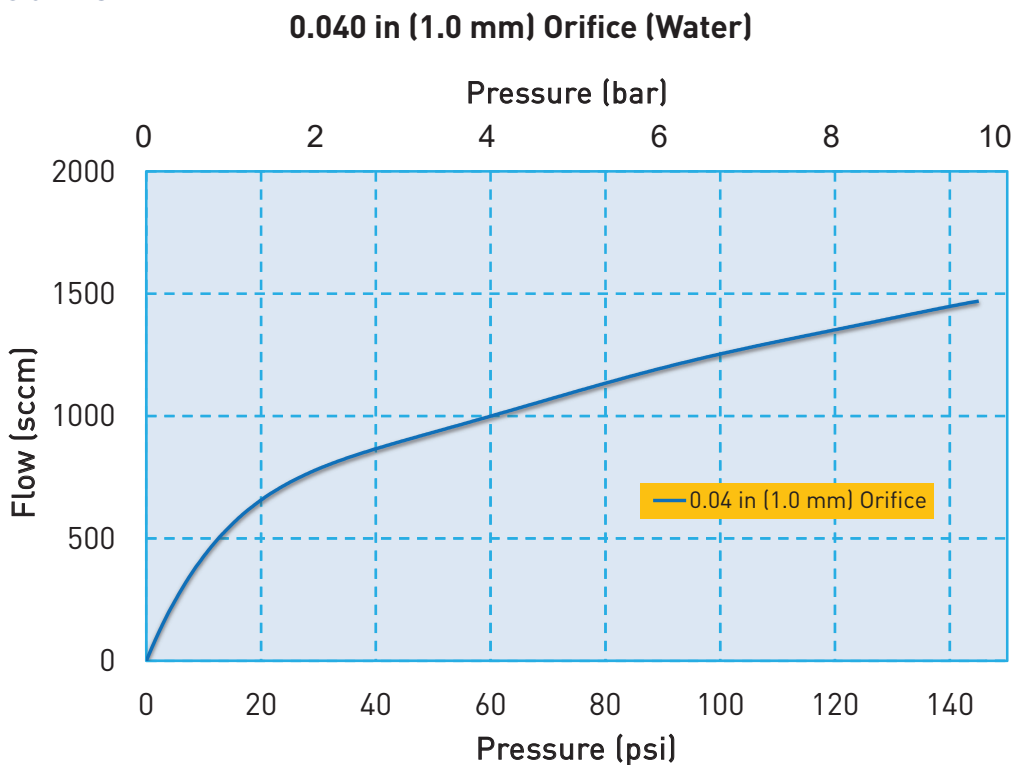

C21 Miniature Liquid Cartridge Valve

Flow Curve

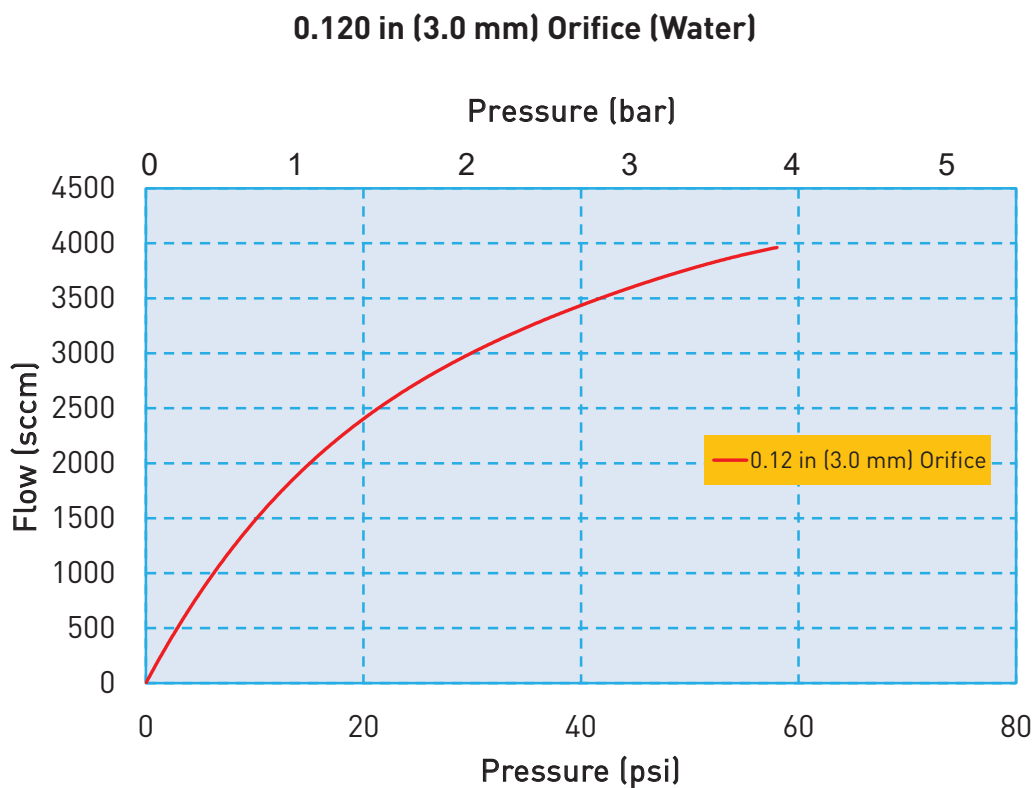
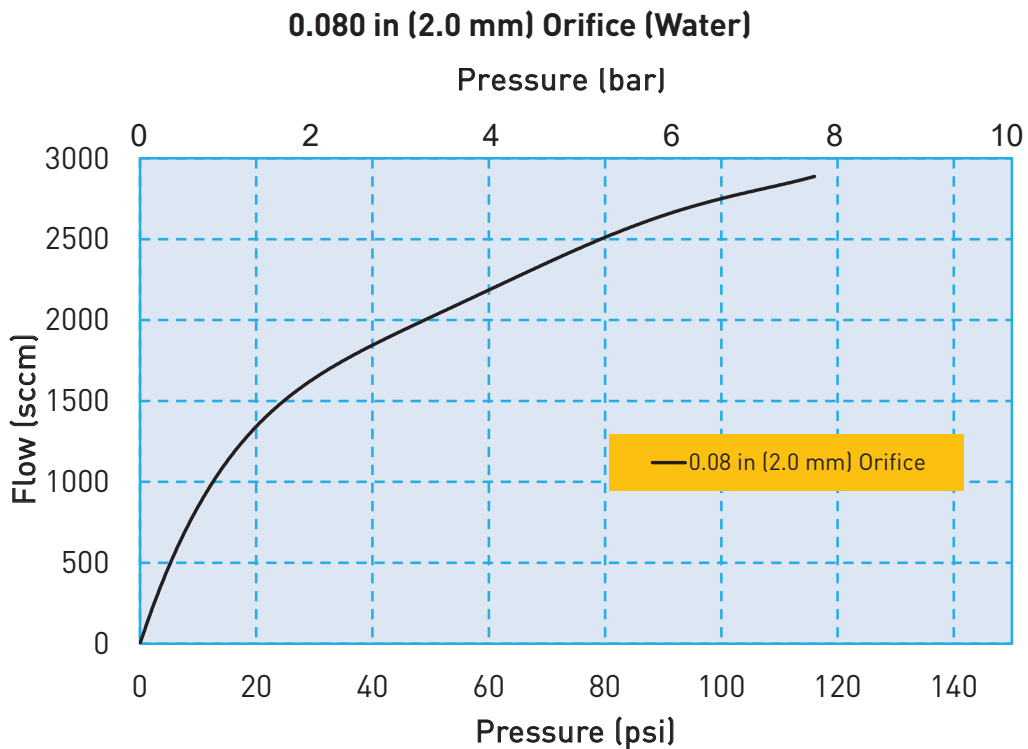

C21 Miniature Liquid Cartridge Valve

Flow Curve

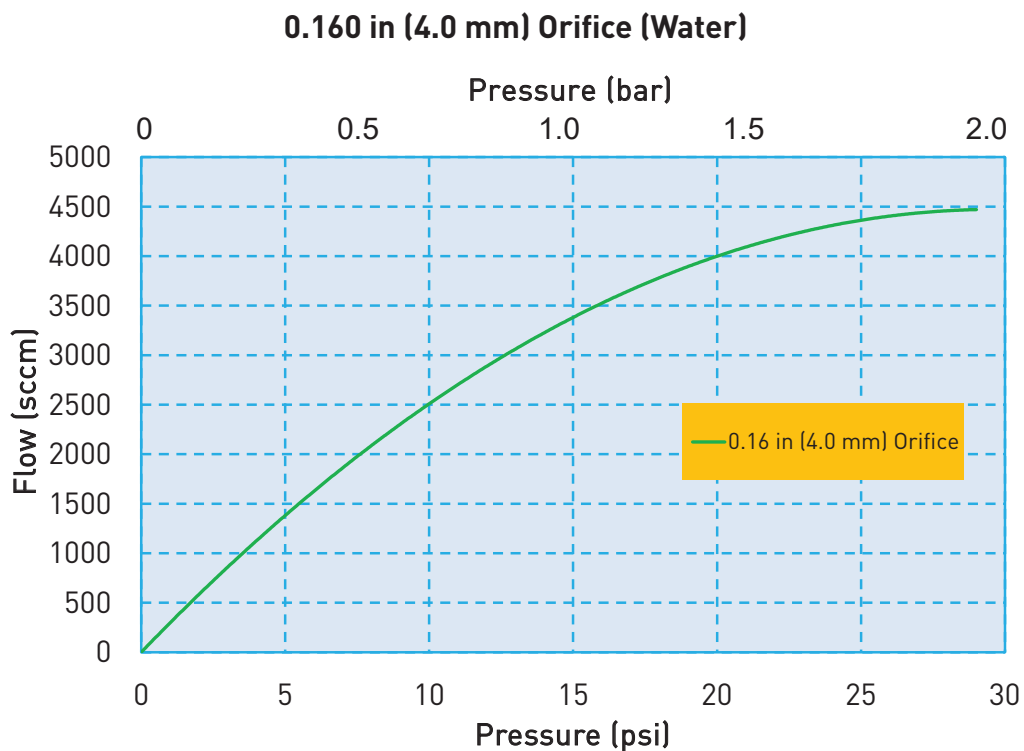

Electrical Interface



Wire Leads

Standard: 3.2 in (80 mm) Wire Leads, stripped at end

C21 Miniature Liquid Cartridge Valve

Electrical Requirements

Table 1

Orifice	0.040 in (1.0 mm)		0.080 in (2.0 mm)		0.12 in (3.0 mm)		0.16 in (4.0 mm)	
Valve Type	2-Way		2-Way		2-Way		2-Way	
Voltage (VDC)*	12	24	12	24	12	24	12	24
Power (Watts)	2.6	2.5	2.6	2.5	2.6	2.5	2.6	2.5
Resistance (Ohm)**	56	235	56	235	56	235	56	235

* ± 5%, other voltages available on request

** ±5% @ 68°F, 20°C

Liquid Interface/Mechanical Integration



C21 Miniature Liquid Cartridge Valve

Dimensions

2-Way Valve Configuration

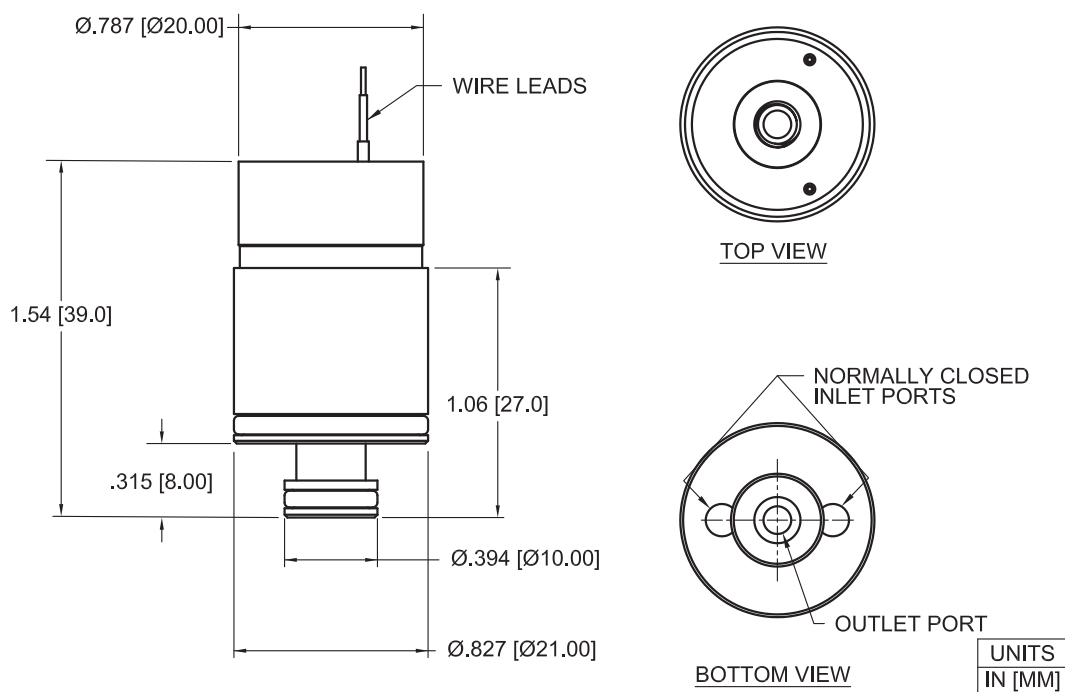

ANSI Symbols

2-Way Normally Closed

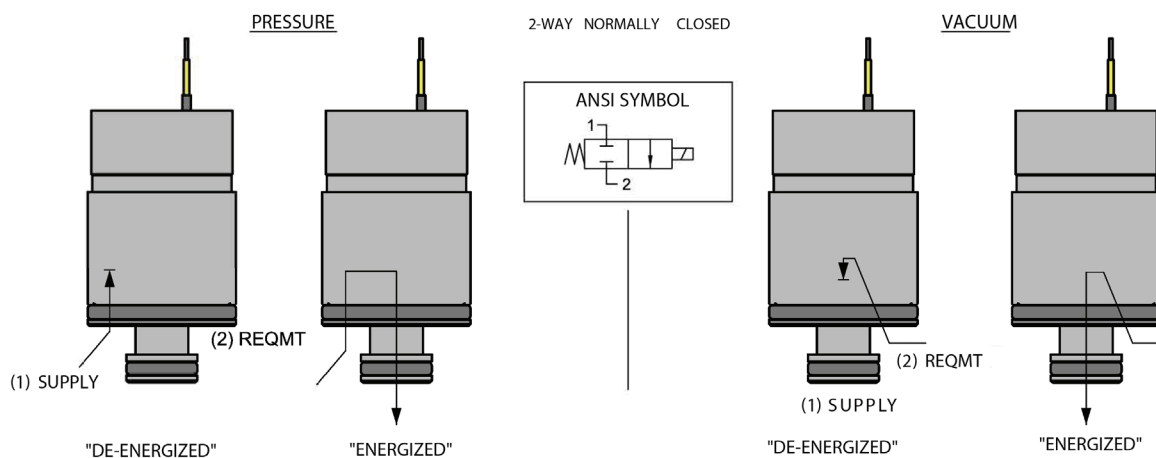

C21 Miniature Liquid Cartridge Valve

Installation and Use

During installation of the C21 valve, the maximum force allowed to press it into the manifold is: 44.96 lbf (200 N)
 Lubrication is recommended (I.E. alcohol or DI water depending on compatibility constraints)

Recommended Valve Manifold Dimensions

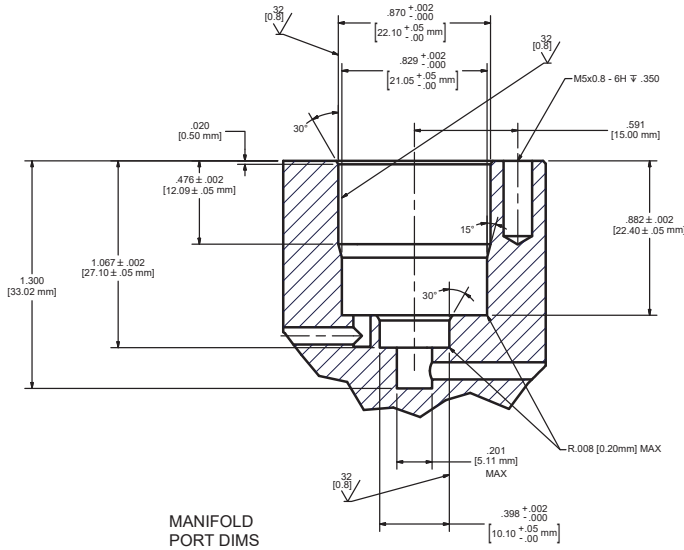

Recommended Valve Mounting

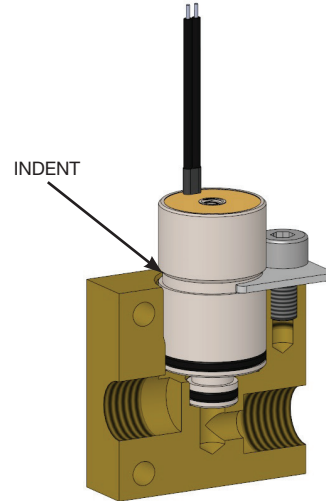

The correct location to use when holding the valve in place in the manifold is the indent at the middle of the valve body. If the top of the valve is used to hold the valve in place, the working pressure the valve will see, can push the valve upward and exceed the maximum insertion force for the valve. This could damage the valve.

Installation and Use

C21 Evaluation Manifold Dimensions and Design C21-MCS

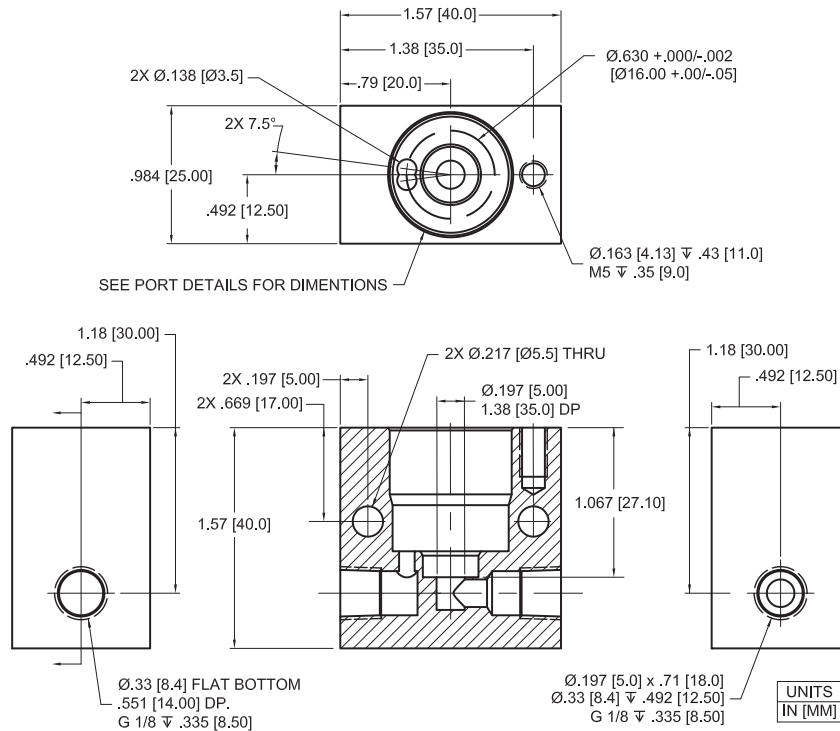

C21 Miniature Liquid Cartridge Valve

Installation and Use

Optional Reduced Power Control Method

“Hit and Hold” is an optional control method to increase power efficiency for the C21 series valves.

Hit and Hold is a common control method used to reduce component power consumption and heat generation without sacrificing performance. The “Hit” or “Spike” state refers to the rated voltage required to actuate the valve. The “Hold” state is a substantial reduction in the rated voltage (normally 50% of the rated voltage) that maintains the valve in an actuated state.

Hit and Hold control can be incorporated using several different approaches, including discrete component circuits or programmable logic. The graph below illustrates a voltage “Hit” and “Hold” control method, however pulse width modulation (PWM) is also an acceptable control method.

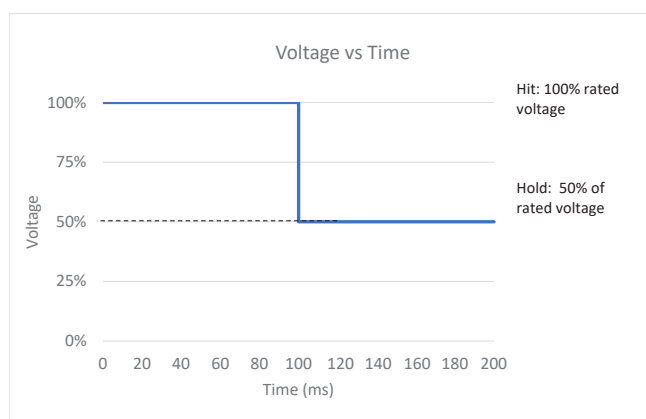

C21 Hit and Hold Specification	
Hit Voltage Level	Rated Voltage
Hold Voltage Level	50% of Rated Voltage
Minimum Hit Time	100 ms
Maximum Hit Time	N/A
PWM Frequency (Minimum)	1 kHz
Hold Nominal Duty Cycle	50%

This method greatly reduces power consumption because the valve only draws full current for a short period of time making it ideal for applications with sensitive power budgets.

Note: 50% duty cycle is a general recommendation; therefore, it is recommended that specific application testing is completed to verify the proper “hold” requirement. Factors that could impact hit and hold voltage levels include vibration, shock, pressure variation and pressure locations that are driven from specific usage. The hit and hold circuit design, combined with Parker’s valve, need to be validated for each specific application to ensure the valve will actuate under all usage conditions. **Contact Factory for more details.**

C21 Miniature Liquid Cartridge Valve

Chemical Compatibility Chart*

Chemical	Seal Options			Other Wetted Materials
	FFKM	FKM	EPDM	Stainless Steel
DI Water	1	1	1	1
Methanol	1	4	1	2
Isopropanol	1	1	1	1
Ethanol	1	3	1	1
Acetonitrile	1	4	1	
Tetrahydrofuran	1	4	4	
Toluene	1	2	4	1
MEK	4	1	1	3
Organic Acids - Dilute	1	1	1	4
Non Organic Acids - Dilute	1	1	1	2
Bases - Dilute	1	1	1	1
Saline	1	1	1	2
Bleach 12%	2	1	1	4
Sodium Hydroxide 20%	1	2	1	2

Compatibility Legend

- EXCELLENT**
Minimal or no effect
- GOOD**
Possible swelling and or loss of physical properties
- DOUBTFUL**
Moderate or severe swelling and loss of physical properties
- NOT RECOMMENDED**
Severe effect and should not be considered

Accessories

C21 Evaluation Manifold with clip and screw (Valve not included)

C21-MCS



Replacement Clip for C21-MCS

C21-C



Replacement Screw for C21-MCS

C21-S



Replacement O-Ring for C21 Valve, Large

C21-LG (FKM)
C21-LGE (EPDM)



Replacement FKM O-Ring for C21 Valve, Small

C21-SM (FKM)
C21-SME (EPDM)



C21 Miniature Liquid Cartridge Valve

Ordering Information

Sample Part ID	C21	-	2	24	FK	10	F	F	-	000
Description	Series	Configuration	Coil Voltage	Elastomer	Orifice	Mounting Style	Electrical Interface	Custom		
Options	C21: 15 mm Cartridge Valve	2: 2-Way	12: 12 VDC 24: 24 VDC	EP: EPDM FK: FKM	10: 0.040 in (1.0 mm) 20: 0.080 in (2.0 mm) 30: 0.12 in (3.0 mm) 40: 0.16 in (4.0 mm)	F: Face Seal	F: 3.2 in (80 mm) flying lead	000: Standard		

Accessories

C21-MCS: C21 Evaluation Manifold with Clip and Screw, Not supplied with the valve.

C21-C: Replacement Clip used on C21-MCS*

C21-S: Replacement Screw used on C21-MCS*

C21-LG: Spare O-Ring for C21 Valve, FKM, Large**

C21-LGE: Spare O-Ring for C21 Valve, EPDM, Large**

C21-SM: Spare O-Ring for C21 Valve, FKM, Small**

C21-SME: Spare O-Ring for C21 Valve, EPDM, Small**

* Not Supplied with Valve, Replacement Part for C21-MCS ** Supplied with Valve

NOTE: For Evaluation - Please Add C21-MCS To Your Sample Order. All Valves Ship With O-Rings Installed

NOTE: In order to provide the best possible solution for your application, please provide the following requirements when contacting Applications Engineering:

- Media, Inlet & Outlet Pressures
- Minimum Required Flow Rate
- System Supply Voltage
- Media & Ambient Temperature Range



Please click on the Order On-line button to configure your C21 valve. For CAD models and more detailed information, please visit us on the Web (www.parker.com/precisionfluidics/C21_LiquidCartridgeValve), call (+1.603.595.1500) or email at ppfinfo@parker.com.

Parker Hannifin Precision Fluidics Division reserves the right to make changes. Drawings are for reference only.

For more information call +1 603 595 1500 or email ppfinfo@parker.com
Visit www.parker.com/precisionfluidics



Series 1 & 2 Miniature Inert PTFE Isolation Valves

2-Way and 3-Way Solenoid Valves



The 2-Way & 3-Way inert Series 1 & 2 valves have been designed for systems where chemical compatibility is most important. The wetted path is isolated from the solenoid and only PTFE and borosilicate glass are in contact with the media passing through the valve. Low internal volume and fast response time ensure repeatable, accurate volumes. Valves will actuate without any pressure or vacuum applied.

Features

- Provides unsurpassed chemical compatibility for a wide range of media with PTFE and borosilicate glass as the only wetted parts
- 100% continuous duty rating in ambient temperatures up to 66°C
- Low power for reduced heat generation and power consumption
- Fast response times for accurate repeatable results
- Direct acting: does not require pressure or vacuum to operate
- 100% tested leak rate provides assurance of a quality seal
- Provides reliable operation for the life of your instrument
- RoHS compliant 

Applications

- Reagent Control
- Solvent Management
- Aggressive Liquid Control

Product Specifications

Physical Properties

Valve Type:	Diaphragm Isolation Valve
Valve Configuration:	3-Way (Series 1) 2-Way, Normally Closed (Series 2)
Media:	Liquids
Operating Environment:	40 to 150°F (4 to 66°C)
Dimensions:	Width: 1.0" (25.4 mm) Height: 2.1" (53.34 mm) Length: 1.0" (25.4 mm)
Porting:	1/4-28 Threaded Ports
Weight:	2.7 oz (76.5 g)
Internal Volume (µL):	96 (3-Way) 49 (2-Way)

Electrical

Voltage (VDC):	12	24
Power (Watts):	2.5	4.2
Current (mA):	211	173
Resistance (Ohm):	57	139
(Ω±5% @ 70°F, 21.1°C)		
Connections:	12" Lead Wire Standard 26 AWG, PTFE Insulated	

Wetted Materials*

Seals:	PTFE
Body Options:	PTFE
All Others:	Borosilicate Glass (3 - Way only)

* See Chemical Compatibility Page
Consult factory for other options

Performance Characteristics

Operating Pressure/Orifice Diameters:	Vacuum - 20 psig (1.4 bar) / 0.060" (1.52 mm)
Proof Pressure:	1.5X rated pressure
Leak Rate:	Bubble Tight
Response Time:	3-Way: <12 ms cycling 2-Way: <20 ms cycling
Recommended Filtration:	10 µm min
Reliability:	Life Cycle Rating of 10 million (Application dependent)

Series 1 & 2 Miniature Inert PTFE Isolation Valves

Typical Flow Curve

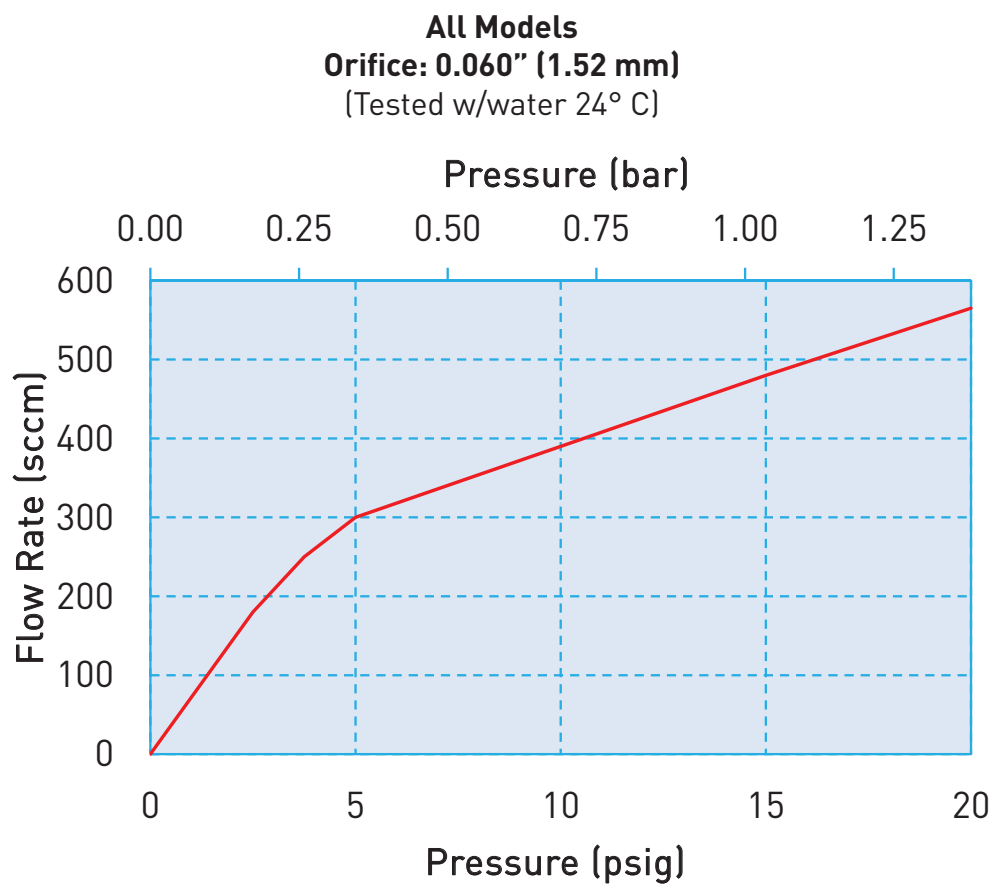

Series 1 & 2 Miniature Inert PTFE Isolation Valves

Electrical Interface

Series 1: 3-Way Wire leads

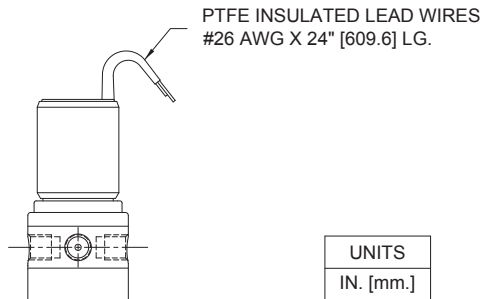

Custom connections available upon request

Mechanical Integration Dimensions

Series 1: 3-Way

3-Way, 0.060" (1.52 mm) Orifice

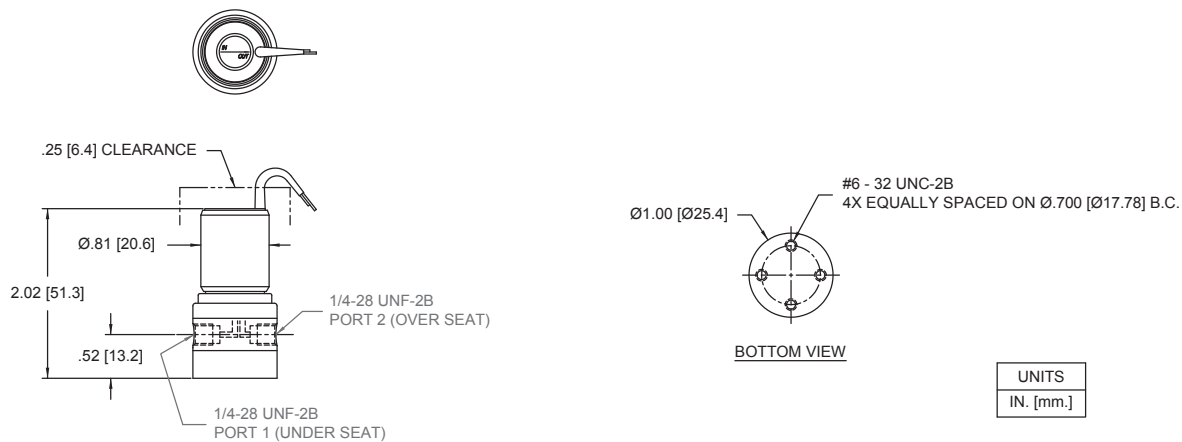

Series 1 & 2 Miniature Inert PTFE Isolation Valves

Electrical Interface

Series 2: 2-Way Wire leads

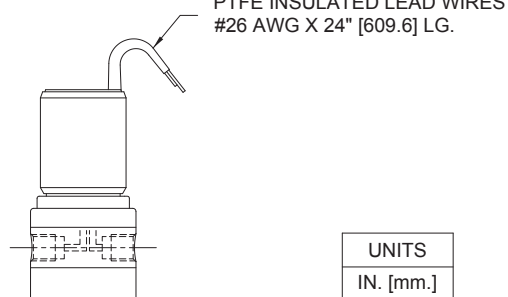

UNITS
IN. [mm.]

Custom connections available upon request

Mechanical Integration Dimensions

Series 2: 2-Way

2-Way, 0.060" (1.52 mm) Orifice

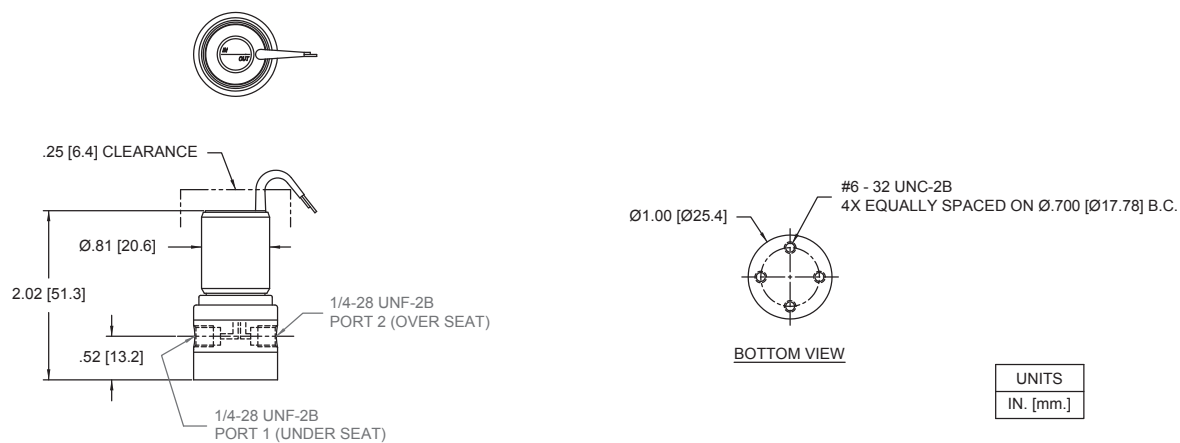

UNITS
IN. [mm.]

Series 1 & 2 Miniature Inert PTFE Isolation Valves

ANSI Symbols

Series 1

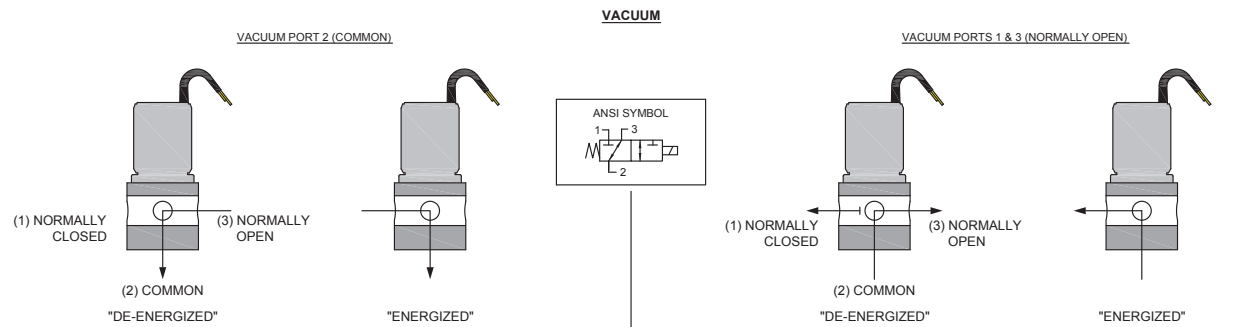
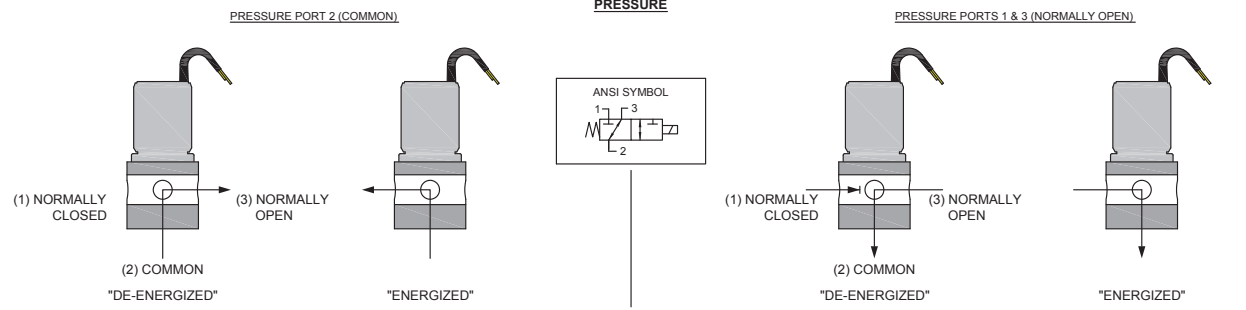

Series 2

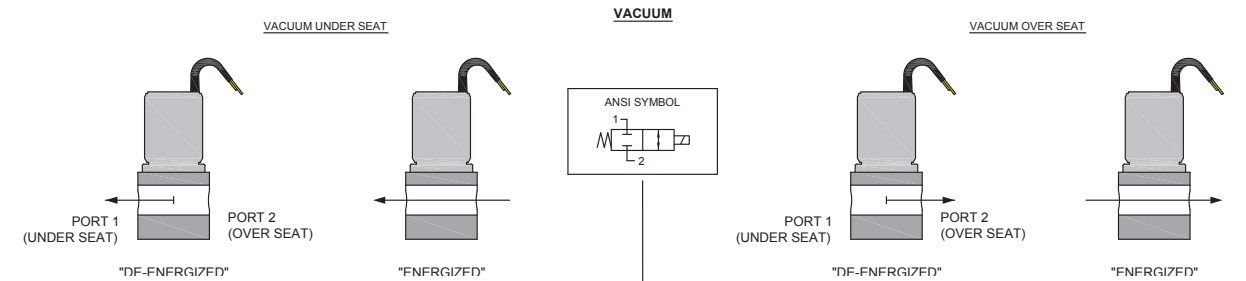
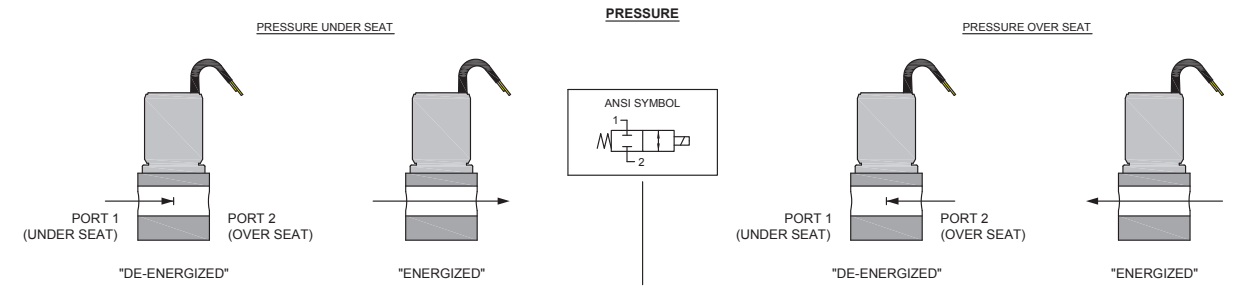

Series 1 & 2 Miniature Inert PTFE Isolation Valves

Hit and Hold Specifications

Hit and Hold is a method for driving valves that can be used to reduce power consumption and heat generation while maintaining valve performance specifications. The valve is "hit" with the full rated voltage for some time period to open it (T1 in the graph) and then "held" open with substantially reduced voltage until the desired pulse length is reached (T2 in the graph). The following table shows the possible holding voltages and power consumption for our standard 12 and 24 VDC solenoids.

<i>Rated Voltage (volts)</i>	<i>3-way</i>		<i>2-way</i>	
	<i>Hold Voltage</i>	<i>Hold Power</i>	<i>Hold Voltage</i>	<i>Hold Power</i>
24	12 volts	1.04 watts	8 volts	0.46 watts
12	6 volts	0.63 watts	5 volts	0.44 watts

Note: Other voltages available

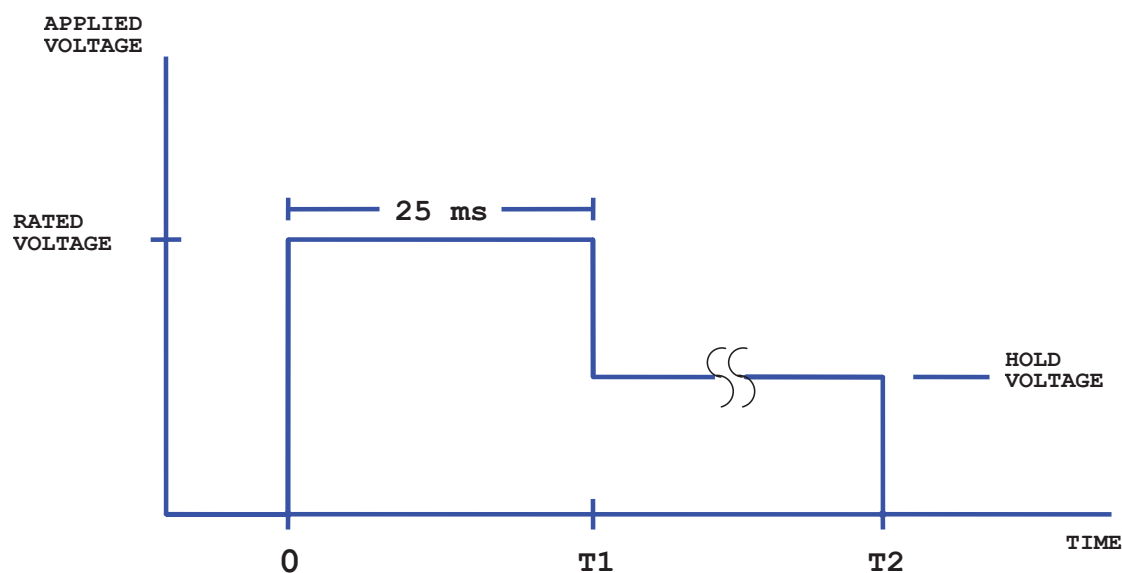

Hold Voltage Graph

Series 1 & 2 Miniature Inert PTFE Isolation Valves

Chemical Compatibility Chart*

Chemical	Diaphragm and Body	Other Wetted Materials
	PTFE	Borosilicate Glass (3-way version only)
DI Water	1	1
Methanol	1	1
Isopropanol	1	1
Ethanol	1	1
Acetonitrile	1	1
Tetrahydrofuran	1	1
Toluene	1	4
Organic Acids - Dilute	1	1
Non Organic Acids - Dilute	1	1
Bases - Dilute	1	1
Saline	1	1
Bleach 12%	1	1
Sodium Hydroxide 20%	1	4

*The above is an Abbreviated Chemical Compatibility Chart. Please consult factory for a complete list.

COMPATIBILITY LEGEND	
1 EXCELLENT	Minimal or no effect
2 GOOD	Possible swelling and/or loss of physical properties
3 DOUBTFUL	Moderate or severe swelling and loss of physical properties
4 NOT RECOMMENDED	Severe effect and should not be considered

Typical Flow Diagram

Air Pressure Over Reagent

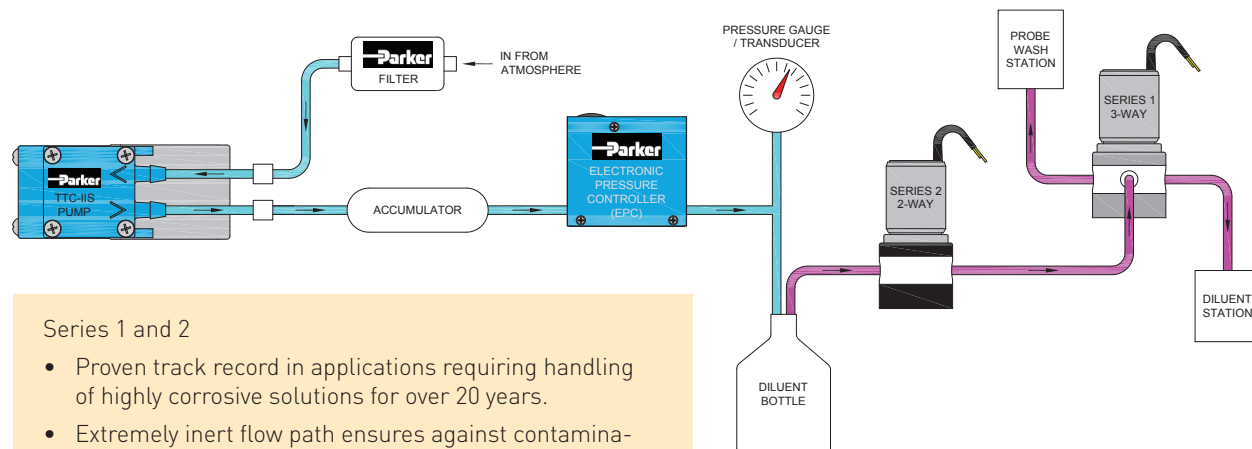

Series 1 and 2

- Proven track record in applications requiring handling of highly corrosive solutions for over 20 years.
- Extremely inert flow path ensures against contamination of sensitive biological fluids.
- Low internal volume reduces carryover and sample/reagent waste.

Highlight test results when available.

Series 1 & 2 Miniature Inert PTFE Isolation Valves

Ordering Information

Orifice Size	Pressure	Seal Material	Valve Type	Voltage	Porting	Part Number
0.060" (1.52mm)	Vac-20psig (1.38 bar)	PTFE	3-Way	12V	1/4"-28	001-0017-900
				24V	1/4"-28	001-0028-900
		PTFE	2-Way NC	12V	1/4"-28	002-0017-900
				24V	1/4"-28	002-0010-900

NOTE: In order to provide the best possible solution for your application, please provide the following requirements when contacting Applications Engineering:

- Media, Inlet & Outlet Pressures
- Minimum Required Flow Rate
- System Supply Voltage
- Media
- Ambient Temperature Range



Please click on the Order On-line button (or go to www.parker.com/precisionfluidics/series1and2) to configure your Series 1 and 2 Miniature Inert PTFE Isolation Valve. For more detailed information, visit us on the Web, or call 603-595-1500.

For more information call +1 603 595 1500 or email ppfinfo@parker.com
Visit www.parker.com/precisionfluidics



Series 3 Miniature Inert Valves

2-Way and 3-Way Liquid Solenoid Valve



The Series 3 solenoid valve is constructed of inert materials suitable for liquids including bleach and saline, for applications in analytical chemistry, clinical diagnostics and ink jet printing. These 2-Way and 3-Way valves handle high flow in a small valve with pressures up to 100 psi and no metal-to-metal sliding surfaces, ensuring long life and trouble free operation. Series 3 also offers a higher pressure rating than most diaphragm isolation valves.

Applications

Control of:

- Bleach
 - Wash solutions
 - Waste removal
 - Reagents
 - Inks
 - Other aggressive media
- Wetted parts are inert plastic (PEEK, PTFE), stainless steel, and elastomer (FKM or EPDM)
 - Chemically resistant to moderate acids, bases, bleach and saline
 - Leak safe design ensures that fluids are contained within the valve preventing damage to the other components in the instrument
 - High flow in small package while providing fast cycle times
 - Resistant to crystallization and particulates
 - No sliding metal-to-metal surfaces minimizes wear of moving parts
 - Direct-acting design does not require pressure or vacuum to operate
 - RoHS compliant 

Product Specifications

Physical Properties

Valve Type:	Inert Non-Isolation Valve
Valve Configuration:	2-Way Normally Closed, 3-Way
Media:	Liquids
Operating Environment:	40 to 150°F (4 to 66°C)
Dimensions:	See page 3
Porting (Orifice Dependent):	Barbs for 1/16" (1.6 mm) ID tubing Barbs for 1/8" (3.2 mm) ID tubing Barbs for 3/16" (4.8 mm) ID tubing Manifold Mount (Contact factory for options)
Weight:	1.8 - 2.0 oz (51 - 56 g)
Internal Volume (µL):	238 (1/16" Barb Option) 326 (1/8" Barb Option) 516 (3/16" Barb Option) 208 (Manifold Option)

Electrical

Voltage (VDC):	12	24
Power (Watts):	2.5	4.2
Current (mA):	211	173
Resistance (Ohm):	57	139
(Ω±5% @ 70°F, 21.1°C)		
Connections:	12" Lead Wires Standard 26 AWG, PTFE Insulated	

Wetted Materials*

Seal:	FKM, EPDM
Body:	PEEK
All Others:	PTFE, Stainless Steel
* See Chemical Compatibility Page Consult factory for other options	

Performance Characteristics

Operating Pressure/ Orifice Diameters:	Vac-100 psig (6.89 bar)/ 0.055" (1.40 mm) Vac-50 psig (3.44 bar)/ 0.078" (1.98 mm) Vac-20 psig (1.36 bar)/ 0.090" (2.29 mm)
Proof Pressure:	1.5X rated pressure
Leak Rate:	Bubble Tight
Response Time:	< 12 ms cycling
Recommended Filtration:	40 µm max
Reliability:	Life Cycle Rating of 10 million (Application dependent)

Series 3 Miniature Inert Valves

Typical Flow Curve

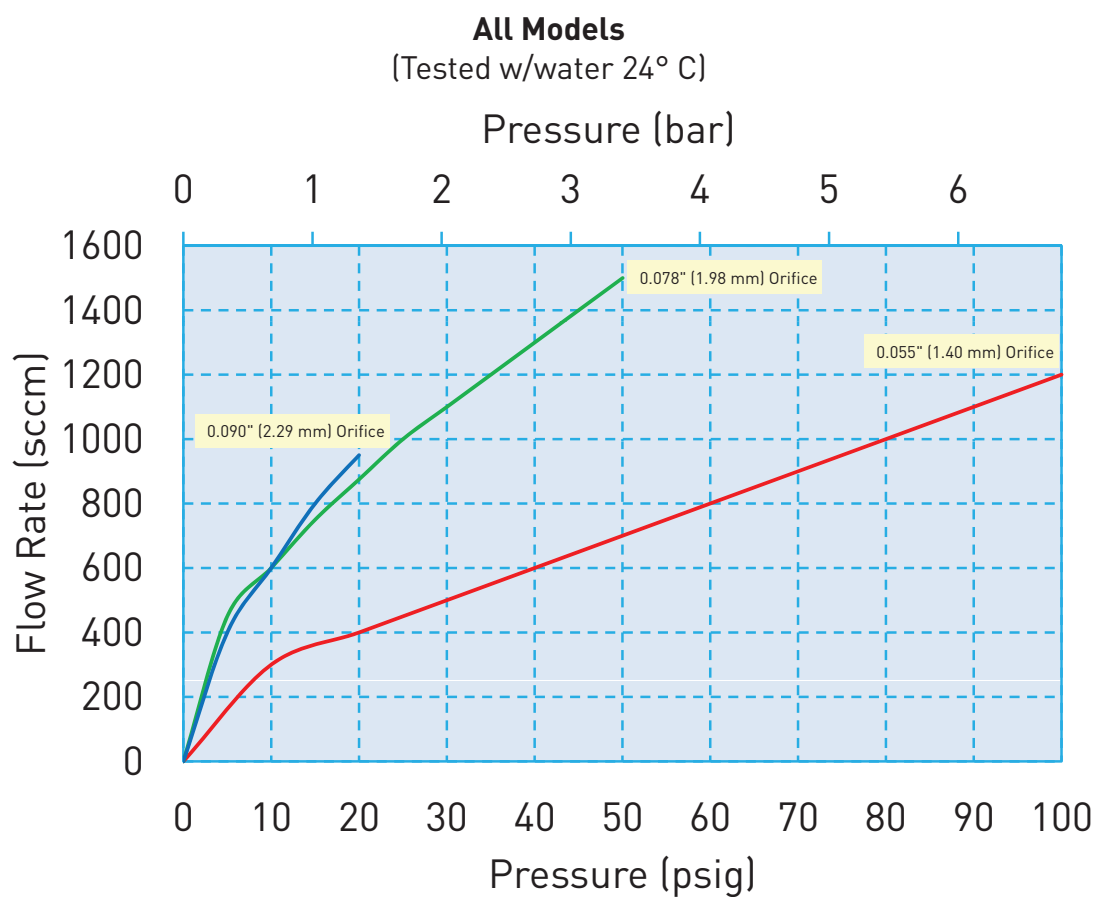

Series 3 Miniature Inert Valves Electrical Interface

Wire leads

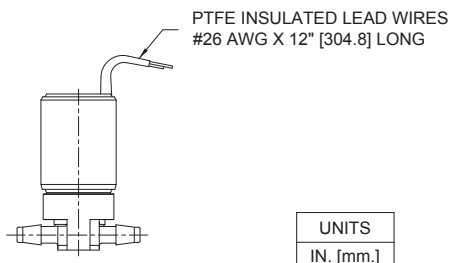

UNITS
IN. [mm.]

Custom connections available upon request

Liquid Interface

Manifold Mount



Barbed



Mechanical Integration Dimensions

Series 3: 2-Way Manifold Mount Dimensions

2-WAY, 0.055" (1.40 mm) ORIFICE, MANIFOLD MOUNT

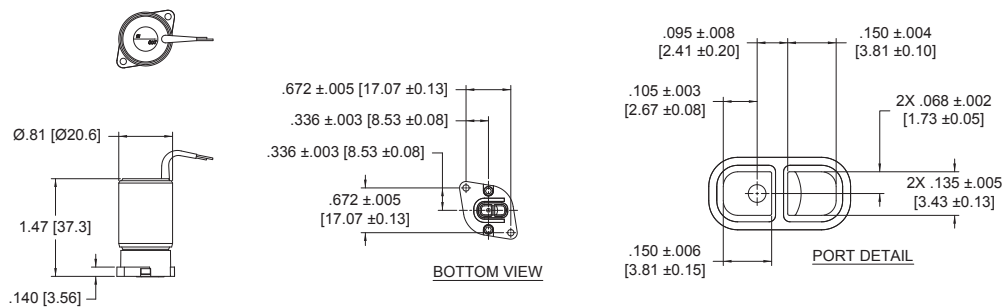

Series 3 Miniature Inert Valves

Mechanical Integration

Dimensions

Series 3: 2-Way Barb

Dimensions

2-WAY, 0.055" (1.40 mm) ORIFICE, 1/16" (1.6 mm) BARB

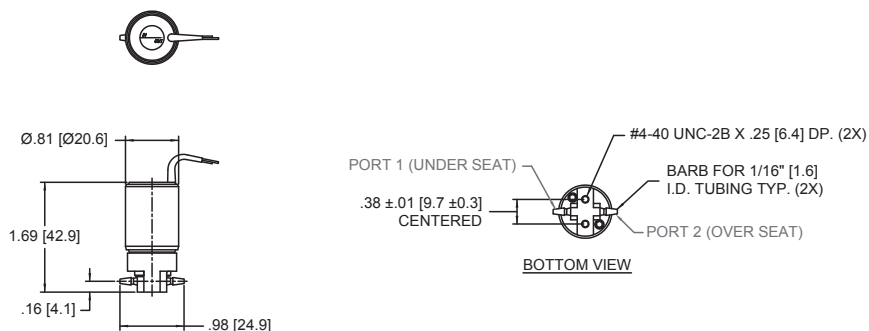

2-WAY, 0.078" (1.98 mm) ORIFICE, 1/8" (3.2 mm) BARB

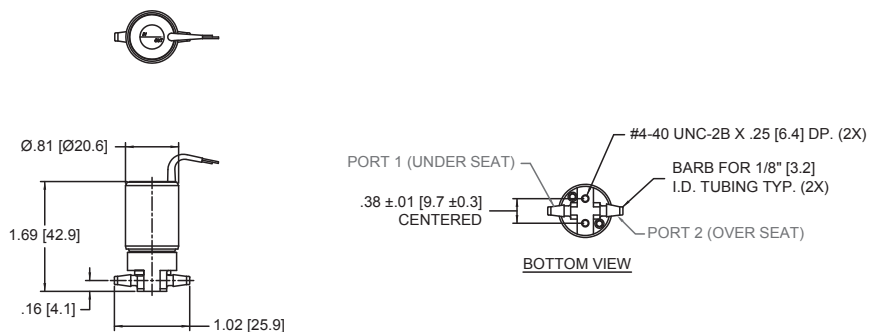

2-WAY, 0.090" (2.29 mm) ORIFICE, 3/16" (4.8 mm) BARB

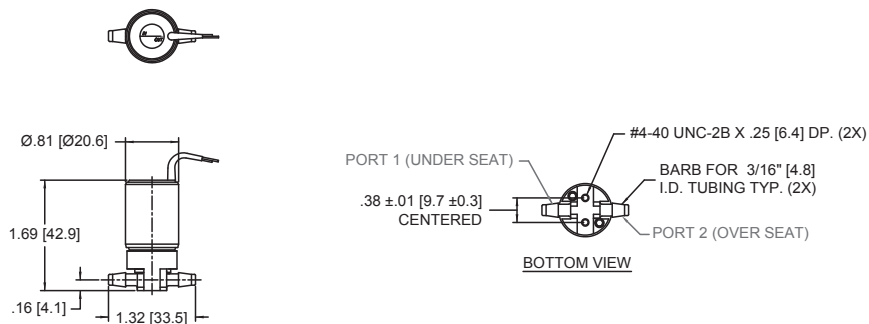

Series 3 Miniature Inert Valves

Mechanical Integration Dimensions

Series 3: 3-Way Barb Dimensions

3-WAY, 0.055" (1.40 mm) ORIFICE, 1/16" (1.6 mm) BARB

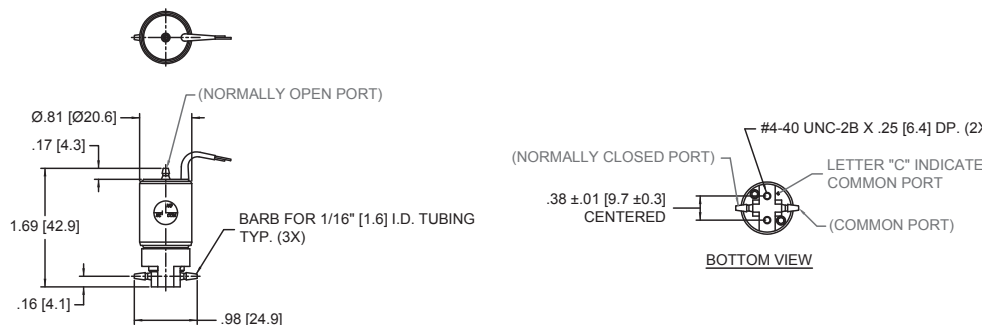

3-WAY, 0.078" (1.98 mm) ORIFICE, 1/8" (3.2 mm) BARB

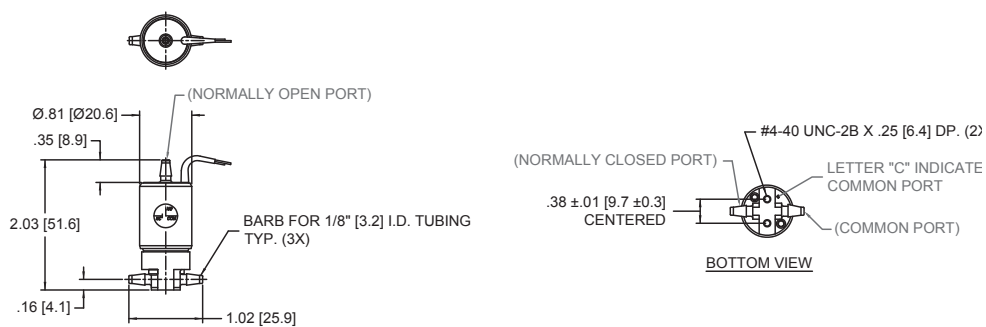

3-WAY, 0.090" (2.29 mm) ORIFICE, 3/16" (4.8 mm) BARB

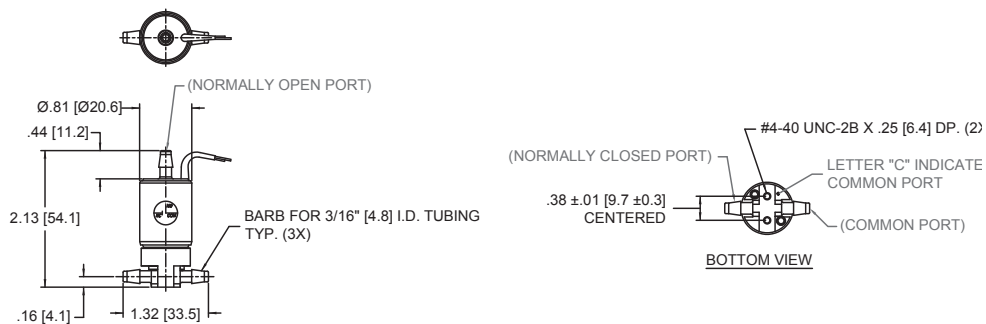

Series 3 Miniature Inert Valves

ANSI Symbols

Pressure 2-Way, Manifold Mount

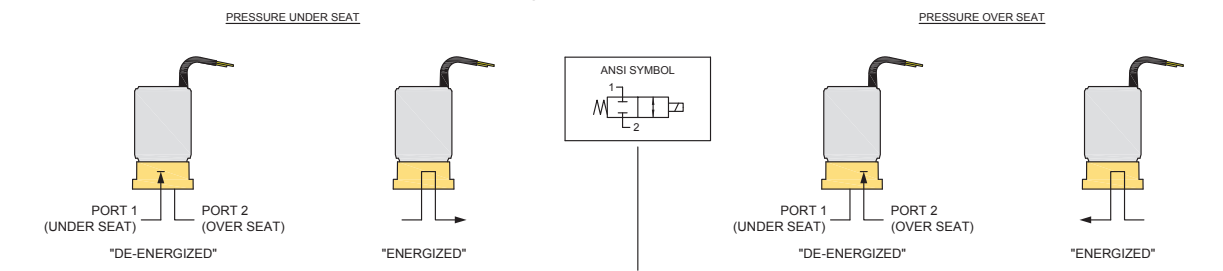

2-Way, Barbed

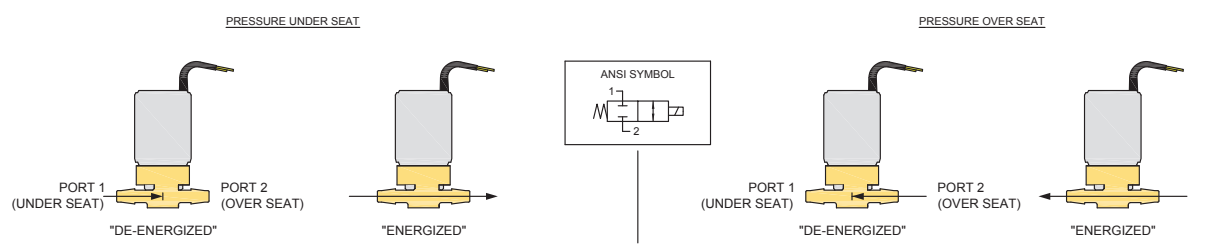

3-Way, Barbed

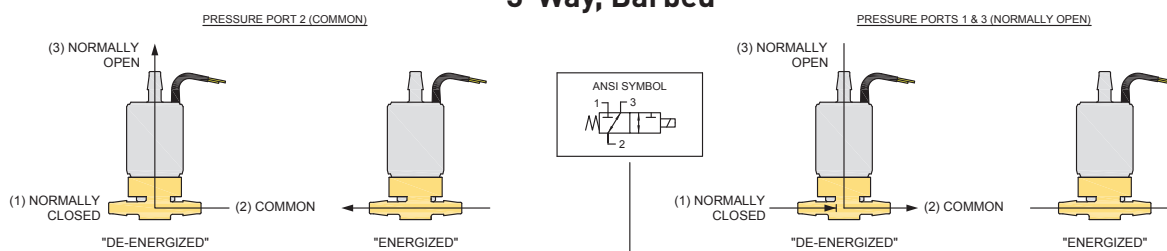

Series 3 Miniature Inert Valves

ANSI Symbols

Vacuum 2-Way, Manifold Mount

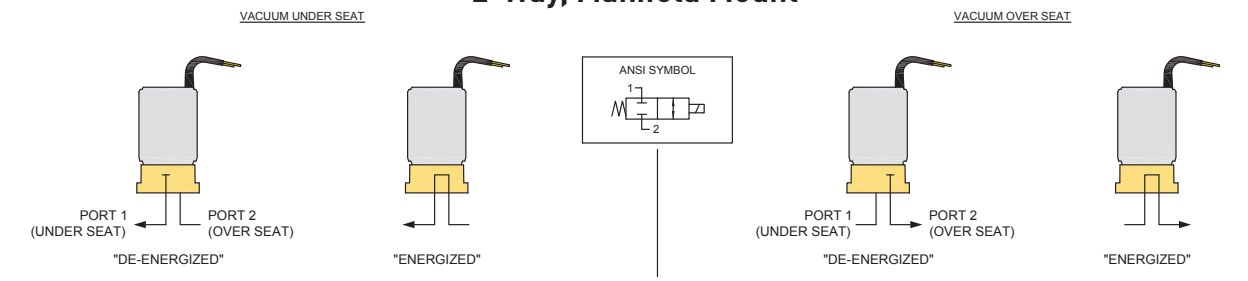

2-Way, Barbed

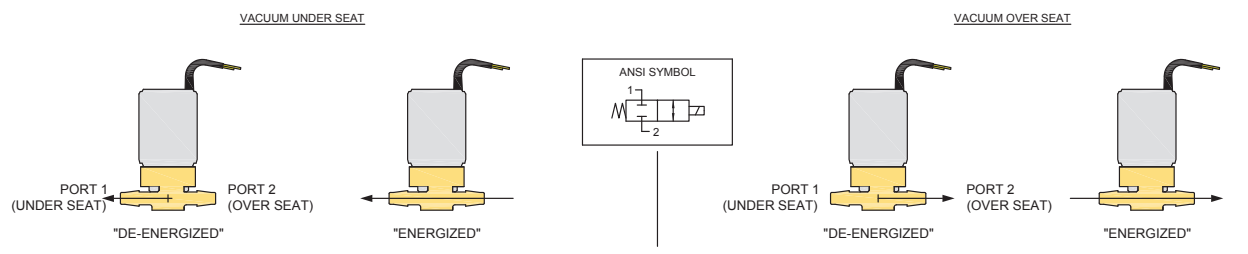

3-Way, Barbed

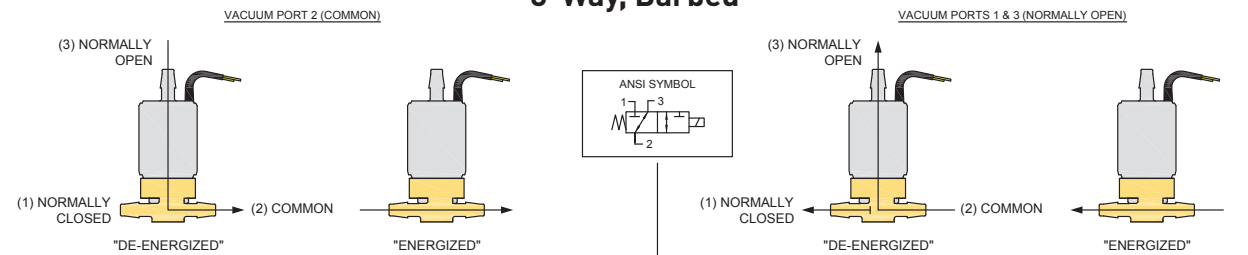

Series 3 Miniature Inert Valves

Hit and Hold Specifications

Hit and Hold is a method for driving valves that can be used to reduce power consumption and heat generation while maintaining valve performance specifications. The valve is "hit" with the full rated voltage for some time period to open it (T1 in the graph) and then "held" open with substantially reduced voltage until the desired pulse length is reached (T2 in the graph). The following table shows the possible holding voltages and power consumption for our standard 12 and 24 VDC solenoids.

Rated Voltage (volts)	3-way		2-way	
	Hold Voltage	Hold Power	Hold Voltage	Hold Power
24	12 volts	1.04 watts	8 volts	0.46 watts
12	6 volts	0.63 watts	5 volts	0.44 watts

Note: Other voltages available

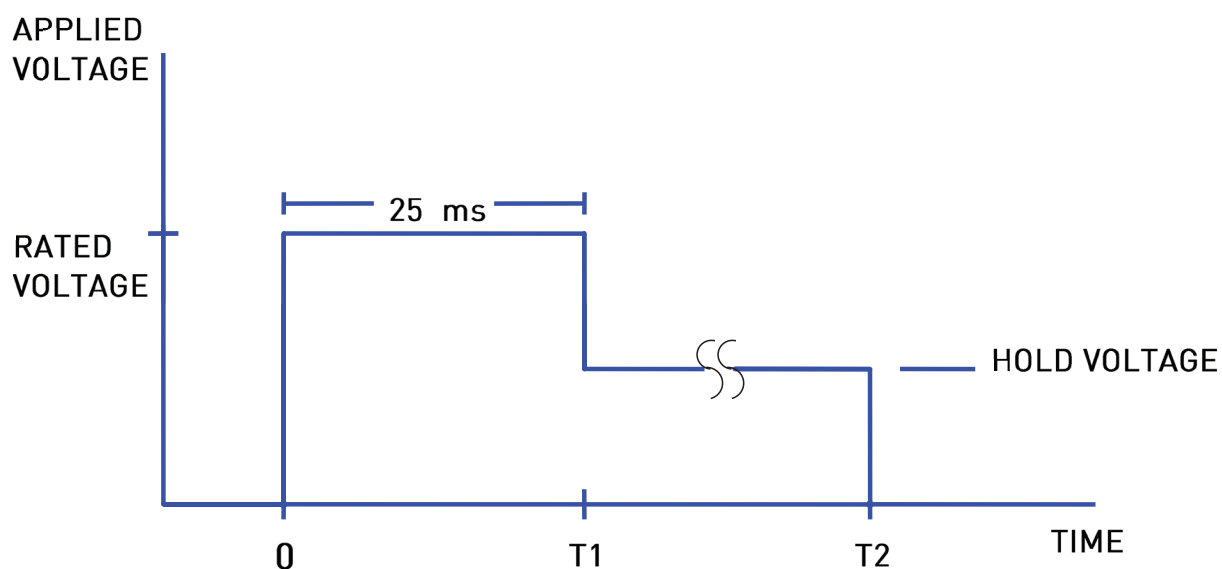

Hold Voltage Graph

Series 3 Miniature Inert Valves

Chemical Compatibility Chart*

Chemical	Seal Options			Other Wetted Materials
	FKM	or	EPDM	PEEK, PTFE & Stainless Steel
DI Water	1		1	1
Methanol	4		1	1
Isopropanol	1		1	1
Ethanol	3		1	1
Acetonitrile	4		1	1
Tetrahydrofuran	4		4	1
Toluene	2		4	1
Organic Acids - Dilute	1		1	1
Non Organic Acids - Dilute	1		1	1
Bases - Dilute	1		1	1
Saline	1		1	1
Bleach 12%	1		1	1 or 2**
Sodium Hydroxide 20%	2		1	1

*The above is an Abbreviated Chemical Compatibility Chart and is for reference purposes only. Please consult factory for a complete list.

**See Ordering Information: 1 = Bleach Part Number 2 = Non Bleach Part Number

COMPATIBILITY LEGEND	
1 EXCELLENT	Minimal or no effect
2 GOOD	Possible swelling and/or loss of physical properties
3 DOUBTFUL	Moderate or severe swelling and loss of physical properties.
4 NOT RECOMMENDED	Severe effect and should not be considered

Typical Flow Diagram

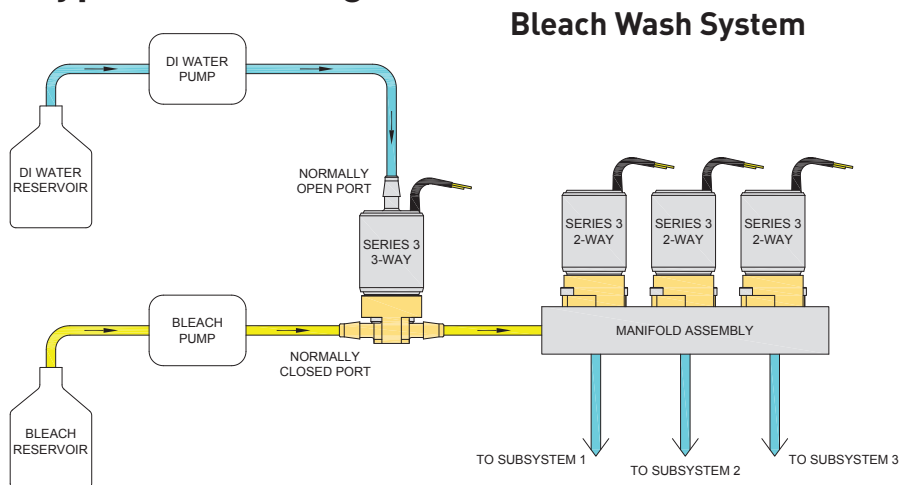

Proven Performance:

- The Series 3 Bleach Valve has been successfully tested to more than six million cycles with no degradation of components.
- Tested with standard bleach concentration used in IVD instrumentation
- Passed specifications for
 - Response time
 - Internal leakage
 - External leakage

The Series 3 Bleach Valve has a proven track record in Clinical Diagnostic Instrumentation for over 25 years.

Series 3 Miniature Inert Valves

Ordering Information

Orifice Size	Pressure	Valve Type	Seal Material	Bleach Compatible	Voltage	Porting	Part Number
0.055" (1.40 mm)	Vac-100 psig (6.89 bar)	2 Way NC	FKM	Yes	12V	1/16" (1.6 mm) Barb	003-0860-900
						Manifold Mount	003-0872-900
					24V	1/16" (1.6 mm) Barb	003-0861-900
					Manifold Mount	003-0873-900	
				No	12V	1/16" (1.6 mm) Barb	003-0137-900
						Manifold Mount	003-0874-900
		24V	1/16" (1.6 mm) Barb		003-0096-900		
			Manifold Mount	003-0875-900			
		3 Way	FKM	Yes	12V	1/16" (1.6 mm) Barb	003-0218-900
						Manifold Mount	003-0219-900
					24V	1/16" (1.6 mm) Barb	003-0863-900
					Manifold Mount	003-0864-900	
No	12V			1/16" (1.6 mm) Barb	003-0130-900		
				Manifold Mount	003-0131-900		
	24V	1/16" (1.6 mm) Barb	003-0194-900				
	Manifold Mount	003-0195-900					
EPDM	No	12V	1/16" (1.6 mm) Barb	003-0218-900			
				Manifold Mount	003-0219-900		
			24V	1/16" (1.6 mm) Barb	003-0264-900		
			Manifold Mount	003-0265-900			
		12V	1/16" (1.6 mm) Barb	003-0862-900			
				Manifold Mount	003-0863-900		
24V	1/16" (1.6 mm) Barb		003-0241-900				
	Manifold Mount	003-0242-900					

Orifice Size	Pressure	Valve Type	Seal Material	Bleach Compatible	Voltage	Porting	Part Number
0.078" (1.98 mm)	Vac-50 psig (3.44 bar)	2 Way NC	FKM	Yes	12V	1/8" (3.2 mm) Barb	003-0864-900
						Manifold Mount	003-0865-900
					24V	1/8" (3.2 mm) Barb	003-0141-900
					Manifold Mount	003-0111-900	
				No	12V	1/8" (3.2 mm) Barb	003-0260-900
						Manifold Mount	003-0261-900
		24V	1/8" (3.2 mm) Barb		003-0257-900		
			Manifold Mount	003-0258-900			
		3 Way	FKM	Yes	12V	1/8" (3.2 mm) Barb	003-0866-900
						Manifold Mount	003-0867-900
					24V	1/8" (3.2 mm) Barb	003-0120-900
					Manifold Mount	003-0165-900	
No	12V			1/8" (3.2 mm) Barb	003-0356-900		
				Manifold Mount	003-0357-900		
	24V	1/8" (3.2 mm) Barb	003-0258-900				
	Manifold Mount	003-0259-900					

Orifice Size	Pressure	Valve Type	Seal Material	Bleach Compatible	Voltage	Porting	Part Number
0.090" (2.29 mm)	Vac-20 psig (1.36 bar)	2 Way NC	FKM	Yes	12V	3/16" (4.8 mm) Barb	003-0868-900
						Manifold Mount	003-0869-900
					24V	3/16" (4.8 mm) Barb	003-0175-900
					Manifold Mount	003-0359-900	
				No	12V	3/16" (4.8 mm) Barb	003-0189-900
						Manifold Mount	003-0376-900
		24V	3/16" (4.8 mm) Barb		003-0870-900		
			Manifold Mount	003-0871-900			
		3 Way	FKM	Yes	12V	3/16" (4.8 mm) Barb	003-0328-900
						Manifold Mount	003-0421-900
					24V	3/16" (4.8 mm) Barb	003-0347-900
					Manifold Mount	003-0348-900	
No	12V			3/16" (4.8 mm) Barb	003-0461-900		
				Manifold Mount	003-0462-900		
	24V	3/16" (4.8 mm) Barb	003-0461-900				
	Manifold Mount	003-0462-900					

NOTE: In order to provide the best possible solution for your application, please provide the following requirements when contacting Applications Engineering:

- Media, Inlet & Outlet Pressures
- Minimum Required Flow Rate
- System Supply Voltage
- Media
- Ambient Temperature Range



Please click on the Order On-line button (or go to www.parker.com/precisionfluidics/s3) to configure your Series 3 Miniature Inert Valve. For more detailed information, visit us on the Web, or call 603-595-1500.

For more information call +1 603 595 1500 or email ppinfo@parker.com
Visit www.parker.com/precisionfluidics



Series 9 Miniature High Speed and Pressure Liquid Dispense Valve

2-Way and 3-Way Solenoid Valve



Series 9 solenoid valves offer outstanding precision control in liquid analysis. Combining high speed, ultra low leak rate, high flow, high pressure and high temperature capability in a small size. This rugged valve operates with extreme repeatability and is constructed of non-corroding, passivated stainless steel. Series 9 coils are rated for continuous duty and are potted to exclude the environment.

Features

- Smallest footprint and highest performance in its class
- High speed response times of less than 6 ms
- 100% tested to leak-tight 1×10^{-7} cc/sec/atm Helium
- Pressures up to 1250 psi (86.2 bar)
- 100% duty cycle in environmental temperatures of up to 221°F (105°C)
- Available with a variety of fittings, orifices, seals, and voltages to match your application
- RoHS compliant 

Applications

- Process Analysis of Liquids
- High Pressure Liquid Control
- Radioactive Liquids in Medical Imaging
- Cooling Circuits

Product Specifications

Physical Properties

Valve Type:	Inert Non-Isolation Valve
Valve Configuration:	2-Way Normally Closed or 3-Way
Media:	Liquids <i>(also capable of handling gasses, for details see the Series 9 Gas datasheet)</i>
Operating Environment:	40 to 221°F (4 to 105°C)
Dimensions:	See pages 4, 5, 6 & 7
Porting (Orifice Dependent):	A-LOK® 1/4 - 28 FNPT compression fittings, VacuSeal
Weight:	3.1 oz (87.9 g) [3-Way, 1/8" NPT Body Option]
Internal Volume (µL):	342.7 to 540.6 (Contact factory for details)

Electrical

Voltage (VDC):	12	24
Power (Watts):	12	12
Current (mA):	1000	500
Resistance (Ohm):	12	48
<i>($\Omega \pm 5\%$ @ 70°F, 21°C)</i>		
Connections:	12" Lead Wires Standard 24 AWG, PTFE Insulated (Custom connectors are available)	

Wetted Materials*

Seals:	FKM or FKM & Vespel
Body:	316 Stainless Steel
All Others:	PTFE, Stainless Steel, FKM
* See Chemical Compatibility Page Consult factory for other options	

Performance Characteristics

Orifice Diameters/ Operating Pressure:	0.030" (0.76 mm) / 1x10 ⁻⁵ Torr -1250 psig (86.2 bar)
	0.060" (1.52 mm) / 1x10 ⁻⁵ Torr - 250 psig (17.2 bar)
	0.116" (2.95 mm) / 1x10 ⁻⁵ Torr - 100 psig (6.9 bar)
Proof Pressure:	1.5X rated pressure
Response Time:	<5 ms 0.030" (0.76 mm) <5 ms 0.060" (1.52 mm) <6 ms 0.116" (2.95 mm)
Leak Rate:	1×10^{-7} cc/sec/atm Helium
Recommended Filtration:	40 µm max

Series 9 Miniature High Speed and Pressure Liquid Dispense Valve

Typical Flow Curve

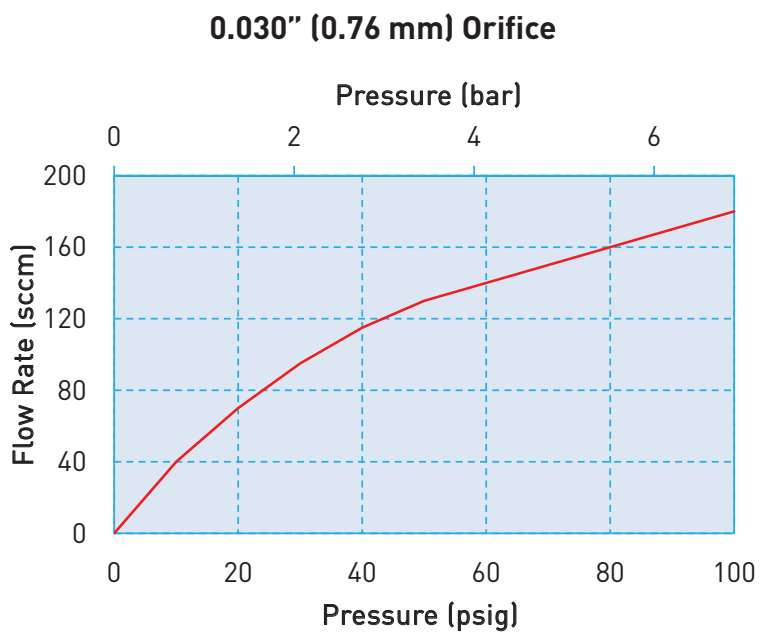
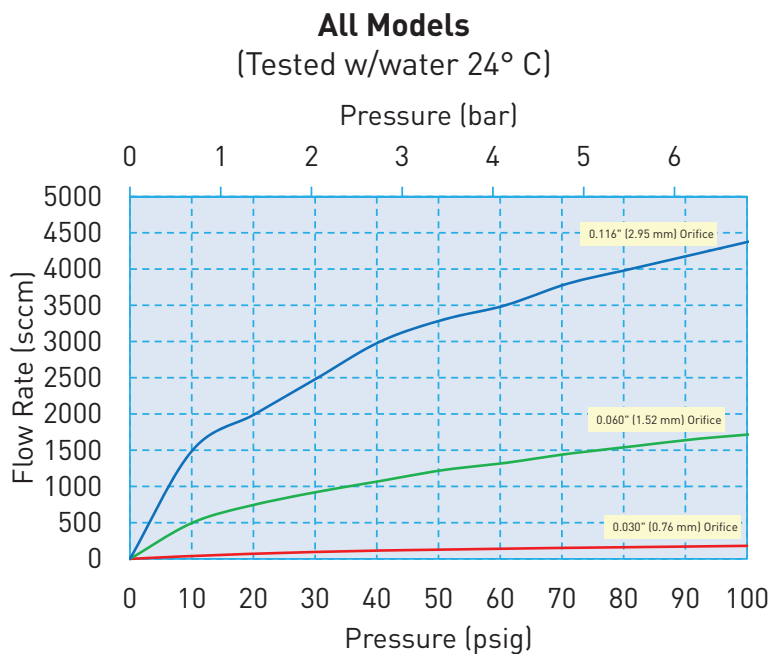

Series 9 Miniature High Speed and Pressure Liquid Dispense Valve

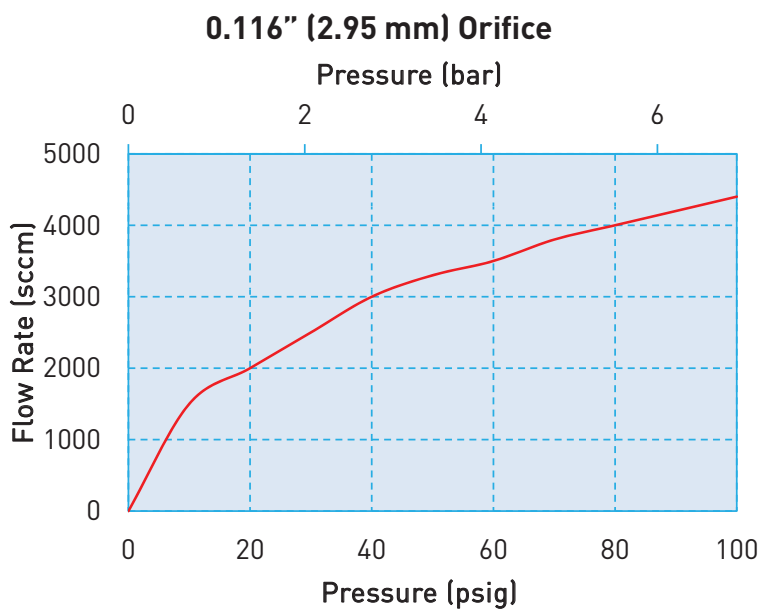
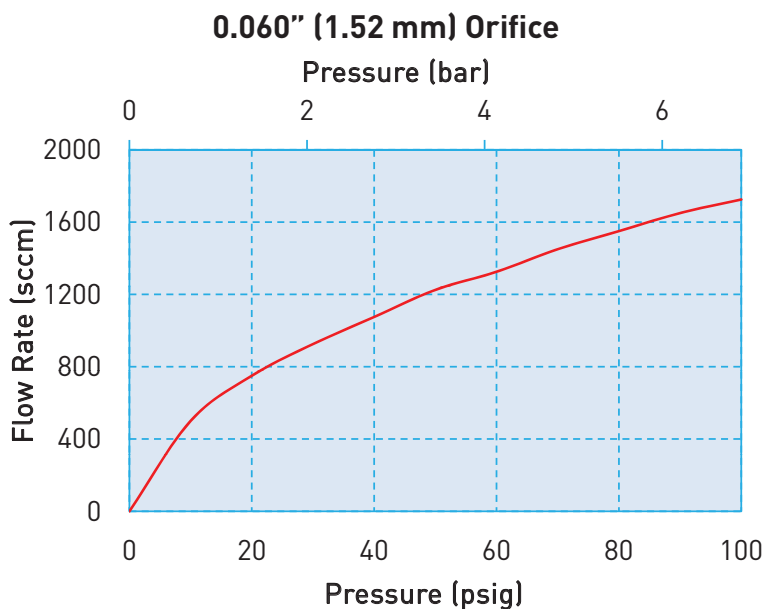

Electrical Interface

Wire leads

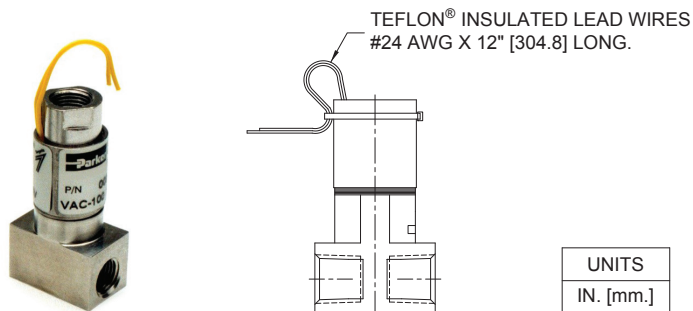

Custom connections available upon request



Series 9 Miniature High Speed and Pressure Liquid Dispense Valve

Mechanical Integration

Dimensions

Series 9: 2-Way Dimensions

2-WAY, 0.030" [0.76 mm] ORIFICE, 1/16" [1.6 mm] A-LOK®

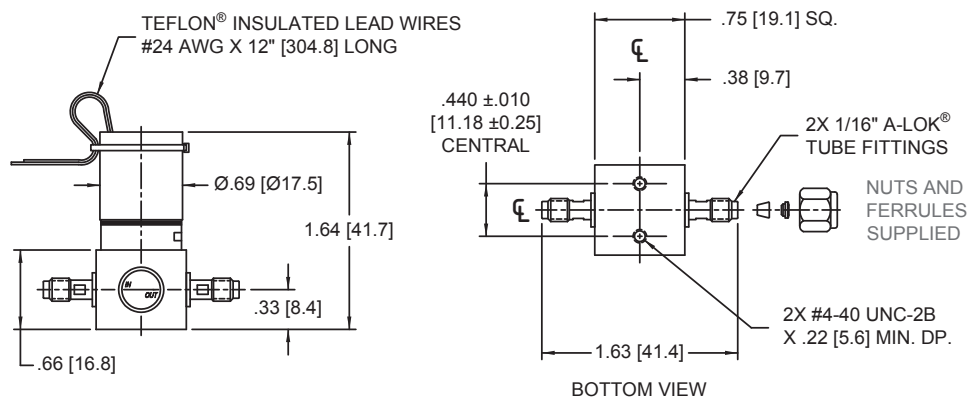

2-WAY, 0.030" [0.76 mm] ORIFICE, 1/4-28 UNF-2B

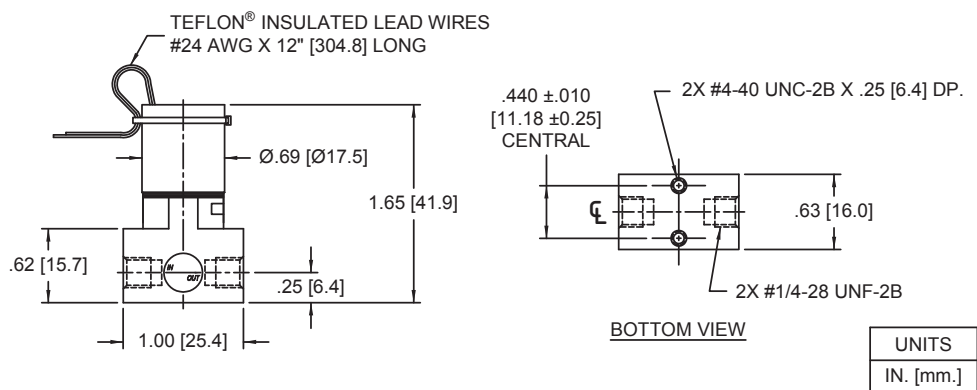

Series 9 Miniature High Speed and Pressure Liquid Dispense Valve

Mechanical Integration

Dimensions

Series 9: 2-Way Dimensions

2-WAY, 0.060" [1.52 mm] ORIFICE, 1/8" [3.18 mm] A-LOK®

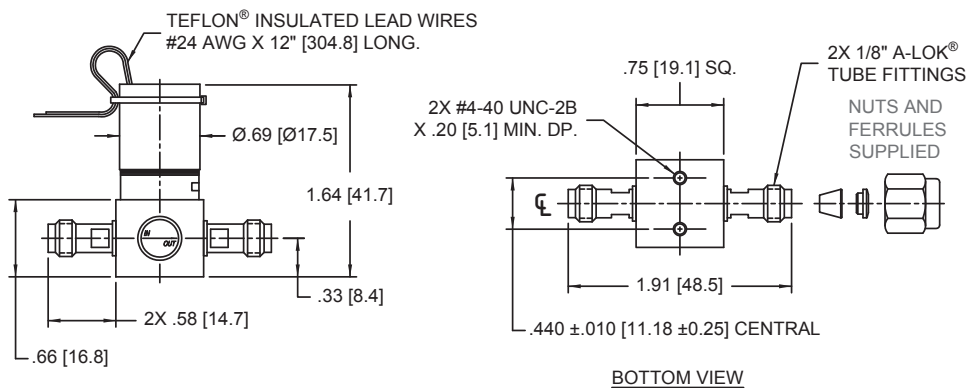

2-WAY, 0.060" [1.52 mm] ORIFICE, 1/8" [3.18 mm] FNPT

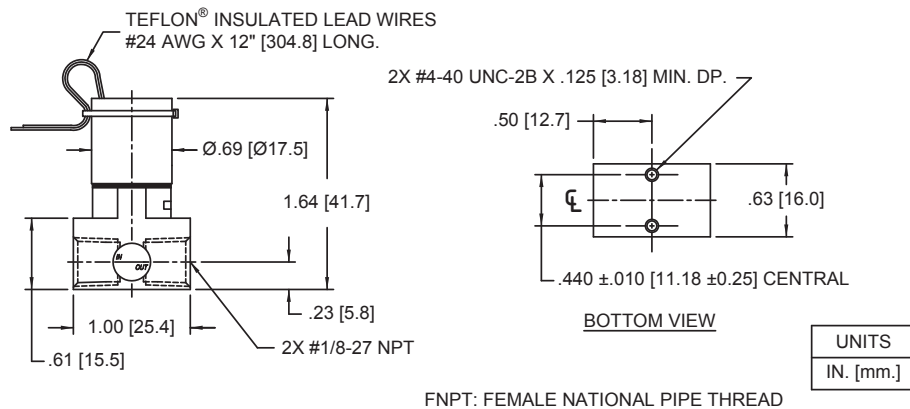

Series 9 Miniature High Speed and Pressure Liquid Dispense Valve

Mechanical Integration

Dimensions

Series 9: 2-Way Dimensions

2-WAY, 0.116" [2.95 mm] ORIFICE, 1/8" [3.18 mm] FNPT

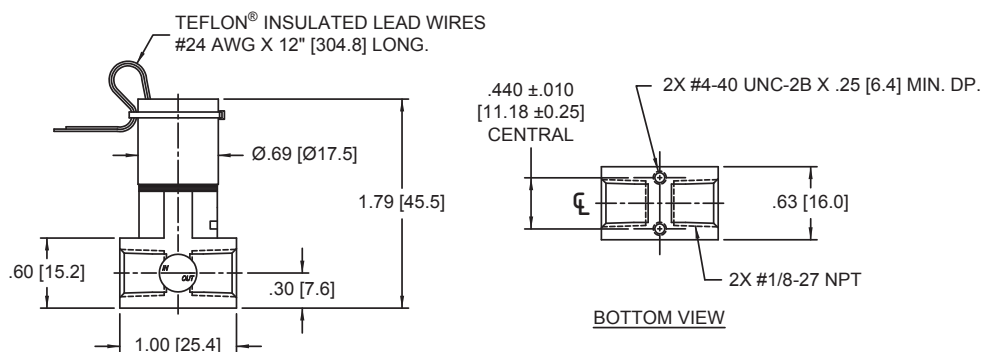

3-WAY, 0.116" [2.95 mm] ORIFICE, 1/8" [3.18 mm] FNPT

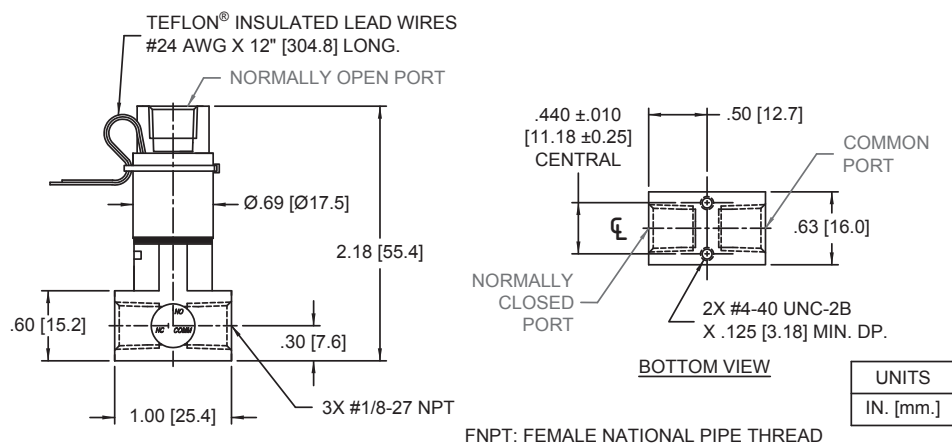

Series 9 Miniature High Speed and Pressure Liquid Dispense Valve

Mechanical Integration

Dimensions

Series 9: 3-Way Dimensions

3-WAY, 0.060" [1.52 mm] ORIFICE, 1/8" [3.18 mm] A-LOK®

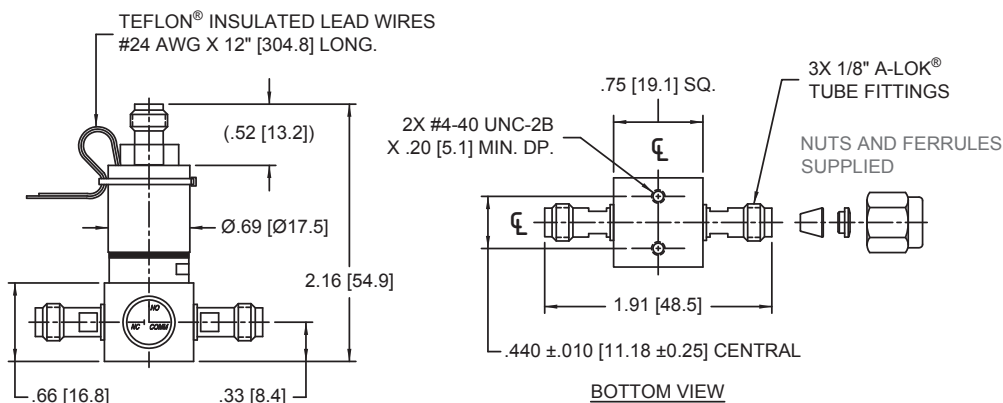

3-WAY, 0.060" [1.52 mm] ORIFICE, 1/8" [3.18 mm] FNPT

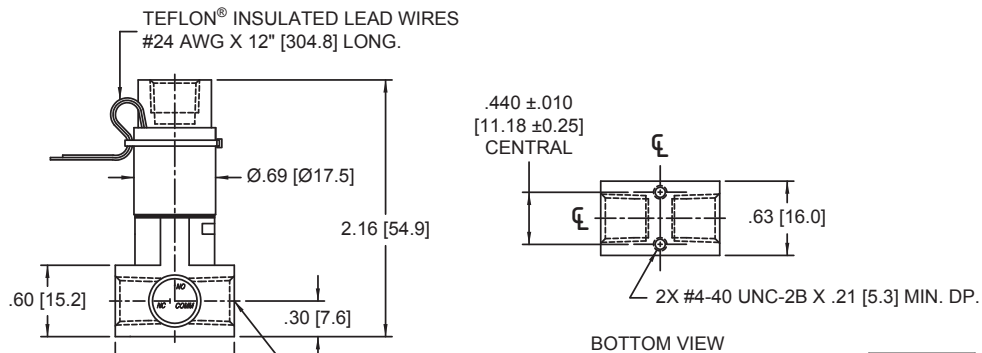

UNITS
IN. [mm.]

FNPT: FEMALE NATIONAL PIPE THREAD

Series 9 Miniature High Speed and Pressure Liquid Dispense Valve

ANSI Symbols

Pressure

2-WAY (1/8" A-LOK® FITTINGS SHOWN)

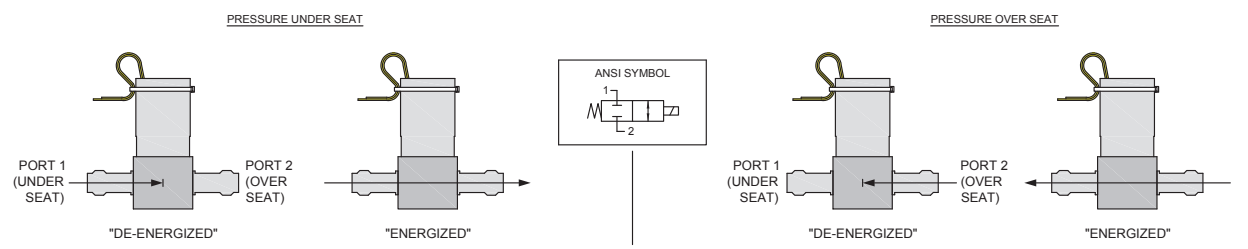

3-WAY (1/8" A-LOK® FITTINGS SHOWN)

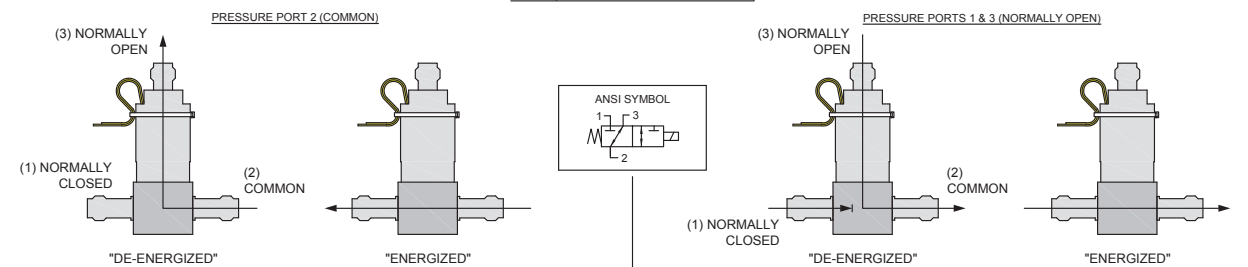

ANSI Symbols

Vacuum

2-WAY (1/8" A-LOK® FITTINGS SHOWN)

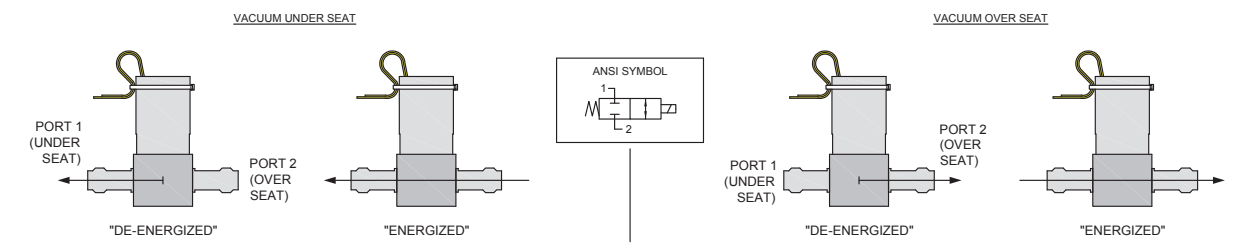

3-WAY (1/8" A-LOK® FITTINGS SHOWN)

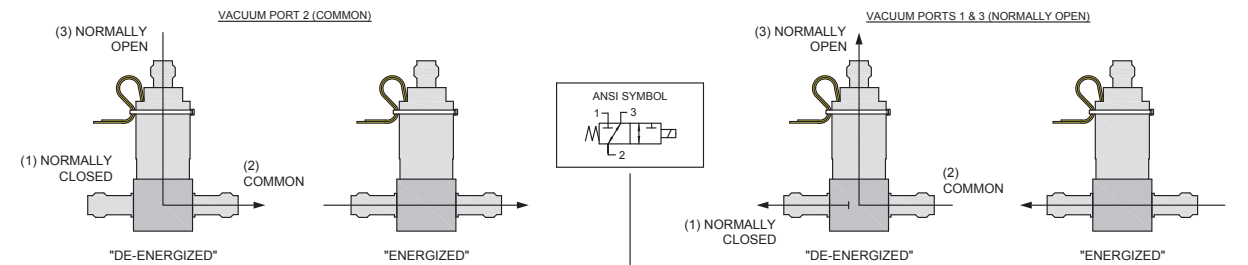

Series 9 Miniature High Speed and Pressure Liquid Dispense Valve

Hit and Hold Specifications (12-Watt coils):

Hit and Hold is a method for driving valves that can be used to reduce power consumption and heat generation while maintaining valve performance specifications. The valve is “hit” with the full rated voltage for some time period to open it (T1 in the graph) and then “held” open with substantially reduced voltage until the desired pulse length is reached (T2 in the graph). The following table shows the possible holding voltages and power consumption for our standard 12 and 24VDC solenoids.

Rated Voltage (volts)	3-way		2-way	
	Hold Voltage	Hold Power	Hold Voltage	Hold Power
24	12 volts	3 watts	5 volts	0.52 watts
12	6 volts	3 watts	5 volts	2.1 watts

Note: Other voltages available

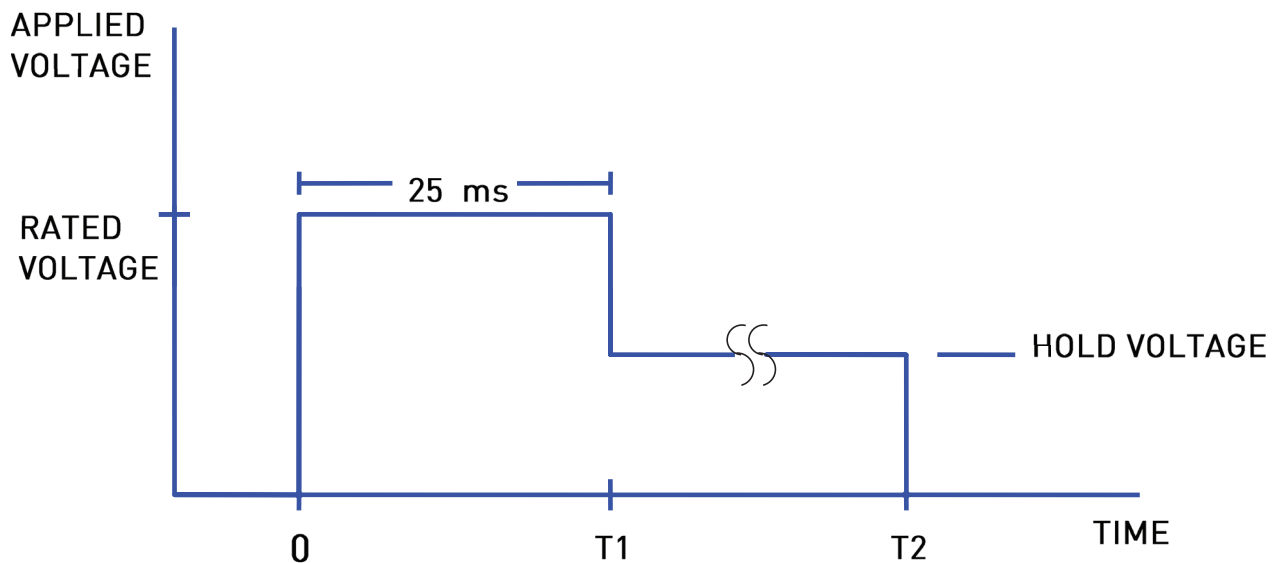

Hold Voltage Graph

Series 9 Miniature High Speed and Pressure Liquid Dispense Valve Chemical Compatibility Chart*

Chemical	Seal Options			Other Wetted Materials	
	FKM and Vespel	or	FKM	PTFE	Stainless Steel
DI Water	1	2	1	1	1
Methanol	4	1	4	1	1
Isopropanol	1	2	1	1	1
Ethanol	3	1	3	1	1
Acetonitrile	4	1	4	1	1
Tetrahydrofuran	4	3	4	1	1
Toluene	2	1	2	1	1
Organic Acids - Dilute	1	1	1	1	1
Non Organic Acids - Dilute	1	1	1	1	1
Bases - Dilute	1	1	1	1	1
Saline	1	1	1	1	1
Bleach 12%	1	4	1	1	2
Sodium Hydroxide 20%	2	4	2	1	1

*The above is an Abbreviated Chemical Compatibility Chart. Please consult factory for a complete list.

COMPATIBILITY LEGEND	
1 EXCELLENT	Minimal or no effect
2 GOOD	Possible swelling and/or loss of physical properties
3 DOUBTFUL	Moderate or severe swelling and loss of physical properties
4 NOT RECOMMENDED	Severe effect and should not be considered

Typical Flow Diagram

Typical Sample Control for Mass Spec

PET RADIO NUCLEOTIDE PRODUCTION (CYCLOTRON)

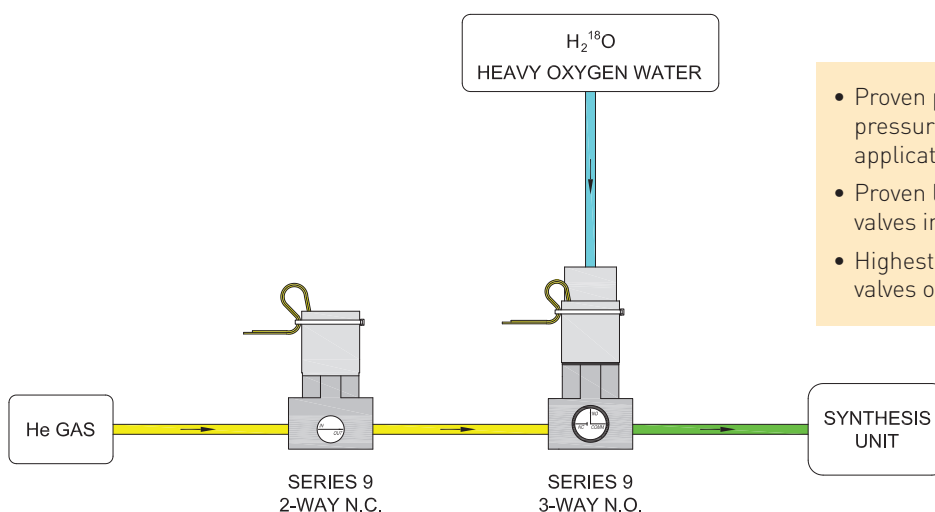

- Proven performance in high pressure and low leak applications using liquids
- Proven lowest leak rate among valves in this form factor.
- Highest pressure capacity in valves of its size.

Series 9 Miniature High Speed and Pressure Liquid Dispense Valve

Ordering Information

Orifice Size	Seal Material	Pressure	Valve Type	Voltage	Porting	Part Number
0.030" (0.76 mm)	Vespel, FKM	Vac-1250 psig (86.2 bar)	2-Way NC	12V	1/16"(1.6mm) A-Lok®	009-0100-900
				24V	1/16"(1.6mm) A-Lok®	009-0172-900
				24V	1/4"(6.4mm)-28	009-0272-900

Orifice Size	Seal Material	Pressure	Valve Type	Voltage	Porting	Part Number
0.060" (1.52 mm)	FKM	Vac-250 psig (17.2 bar)	2-Way NC	24V	1/8"(3.2mm) A-Lok®	009-0270-900
				24V	1/8"(3.2mm) FNPT	009-0631-900
				12V	1/8"(3.2mm)FNPT	091-0094-900
		Vac-100psig (6.89 bar)	3-Way	24V	1/8"(3.2mm)A-Lok®	009-0269-900
				24V	1/8"(3.2mm)FNPT	009-0933-900

Orifice Size	Seal Material	Pressure	Valve Type	Voltage	Porting	Part Number
0.116" (2.95 mm)	FKM	Vac-100 psig (6.89 bar)	2-Way NC	24V	1/8"(3.2mm)FNPT	009-0089-900
			3-Way	12V	1/8"(3.2mm) FNPT	009-0207-900
				24V	1/8"(3.2mm) FNPT	009-0143-900

NOTE: In order to provide the best possible solution for your application, please provide the following requirements when contacting Applications Engineering:

- Media, Inlet & Outlet Pressures
- Minimum Required Flow Rate
- System Supply Voltage
- Media
- Ambient Temperature Range



Please click on the Order On-line button (or go to www.parker.com/precisionfluidics/s9) to configure your Series 9 Miniature High Speed and Pressure Liquid Dispense Valve. For more detailed information, visit us on the Web, or call 603-595-1500.

For more information call +1 603 595 1500 or email ppinfo@parker.com
Visit www.parker.com/precisionfluidics



Series 99

Miniature High Speed and Pressure Liquid Dispense Valve

2- and 3-Way Liquid Solenoid Valve

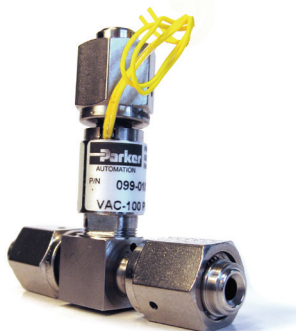

Applications

- Liquid CO₂ Dispense
- Surgical Refrigerant Dispense
- Semiconductor Refrigerant Dispense

Series 99 solenoid valves offer outstanding potential for precision control in liquid analysis. Combining high speed, ultra low leak rate, high flow, high pressure and high temperature capability, in a small size. This rugged valve operates with extreme repeatability and is constructed of non-corroding, passivated stainless steel. Series 99 coils are rated for continuous duty and are potted to exclude the environment.

Features

- Smallest footprint and highest performance in its class
- 100% duty cycle in environmental temperatures of up to 221°F (105°C)
- High speed response times of less than 5 ms eliminate delays in the system
- 100% tested to leak-tight 1 x 10⁻⁸ cc/sec/atm Helium
- Pressures up to 1250 PSI (86.2 bar)
- Available with a variety of fittings, orifices, seals, and voltages to match your application
- RoHS compliant 

Product Specifications

Physical Properties

Valve Type:	Inert Non-Isolation Valve
Valve Configuration (Type):	2-Way Normally Closed or 3-Way
Media:	Liquids (also capable of handling gasses, for details see the Series 9 Gas datasheet)
Operating Environment:	40 to 221°F (4 to 105°C)
Dimensions:	See pages 4, 5 & 6
Porting (Orifice Dependent):	A-LOK® compression fittings, VacuSeal
Weight:	3.1 oz (88.9 g) [3-Way, 1/8" NPT Body Option]
Internal Volume (µL):	354.5 to 593.8 micro liter (Contact factory for details)

Electrical

Voltage (VDC):	12	24
Power (Watts):	12	12
Current (mA):	1000	500
Resistance (Ohm):	12	48
(Ω±5% @ 70°F, 21°C)		
Connections:	12" Lead Wires Standard 24 AWG, PTFE Insulated	

Wetted Materials*

Seals:	Vespel & Silver-Plated Nickel or FKM & Silver-Plated Nickel
Body:	316 Stainless Steel
All Others:	PTFE, Stainless Steel, Body, Seals
* See Chemical Compatibility Page Consult factory for other options	

Performance Characteristics

Orifice Diameters/ Operating Pressure:	0.030" (0.76 mm) / 1x10 ⁻⁵ Torr -1250 psig (86.2 bar)
	0.060" (1.52 mm) / 1x10 ⁻⁵ Torr - 250 psig (17.2 bar)
	0.116" (2.95 mm) / 1x10 ⁻⁵ Torr - 100 psig (6.9 bar)
Proof Pressure:	1.5X rated pressure
Leak Rate:	1 x 10 ⁻⁸ cc/sec/atm Helium
Response Time:	<5 ms 0.030" (0.76 mm) <5 ms 0.060" (1.52 mm) <6 ms 0.116" (2.95 mm)
Recommended Filtration:	40 µm max

Series 99 Miniature High Speed and Pressure Liquid Dispense Valve

Typical Flow Curve

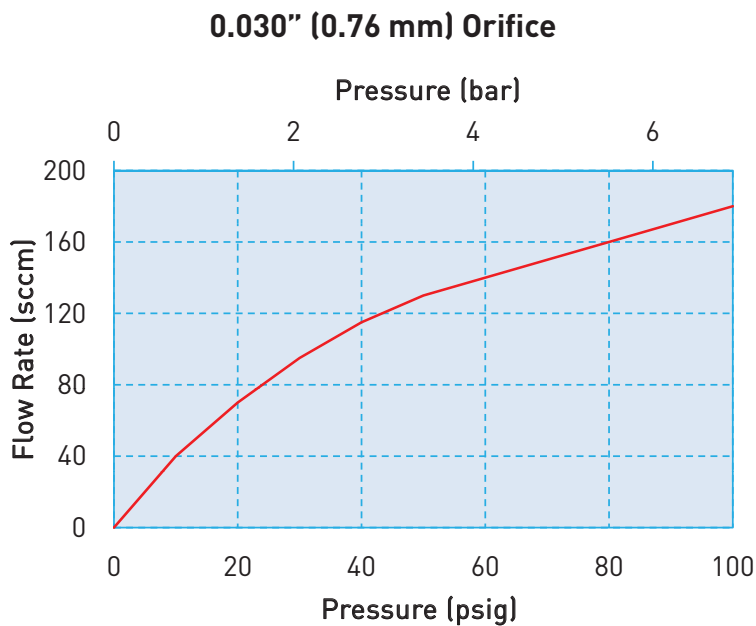
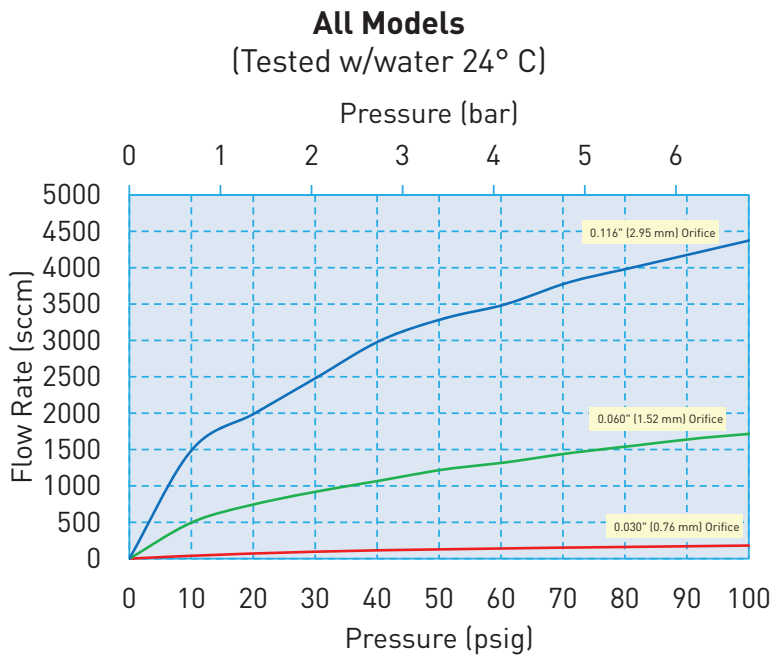

Series 99 Miniature High Speed and Pressure Liquid Dispense Valve

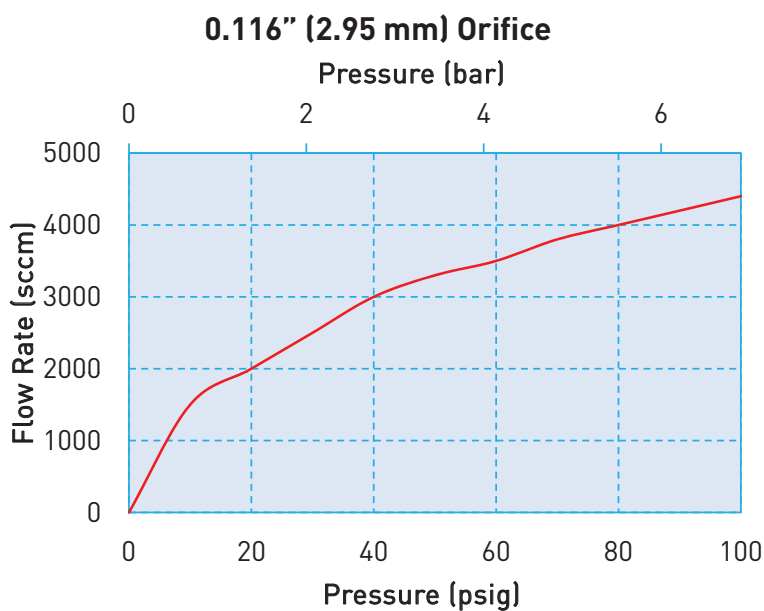
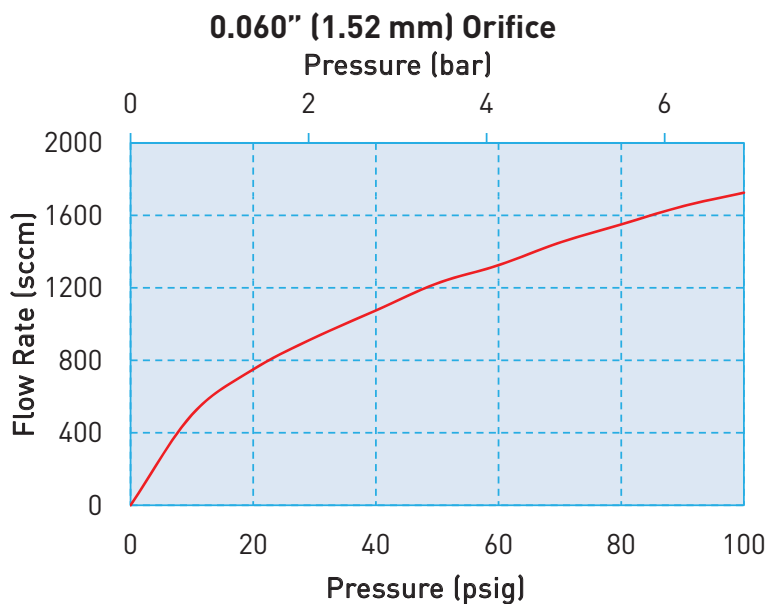

Electrical Interface

Wire leads

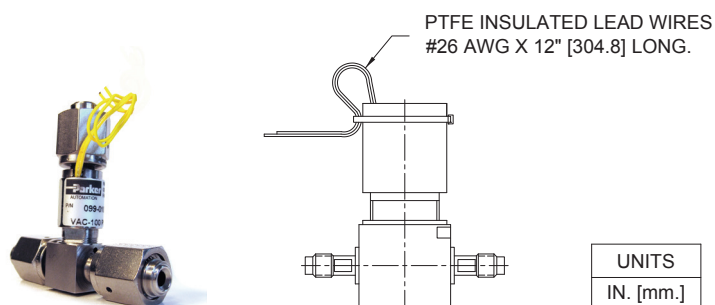

Custom connections available upon request



Series 99 Miniature High Speed and Pressure Liquid Dispense Valve

Mechanical Integration

Dimensions

Series 99: 2-Way Dimensions

2-WAY, 0.030" [0.76 mm] ORIFICE, 1/16" [1.6 mm] A-LOK®

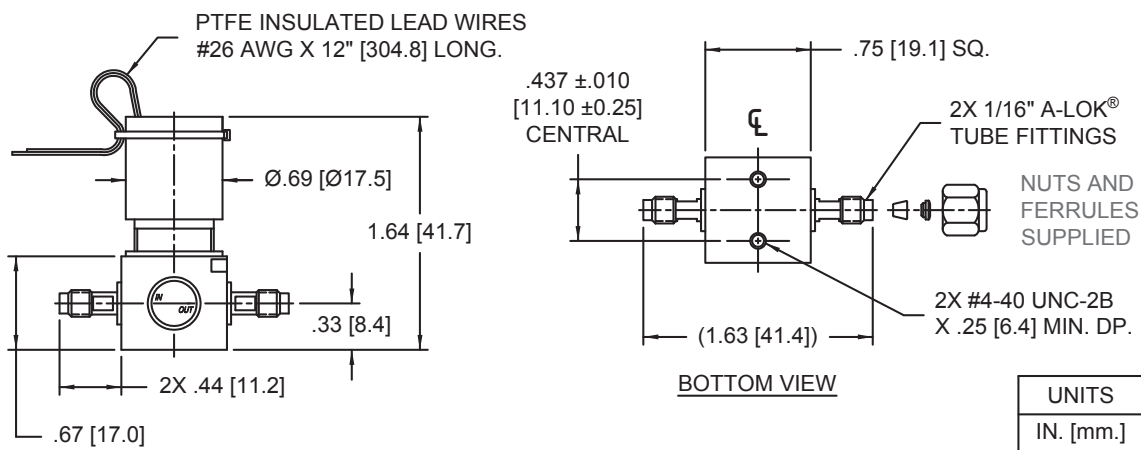

Series 99 Miniature High Speed and Pressure Liquid Dispense Valve

Mechanical Integration

Dimensions

Series 99: 2-Way Dimensions

2-WAY, 0.060" [1.52 mm] ORIFICE, 1/8" [3.18 mm] A-LOK®

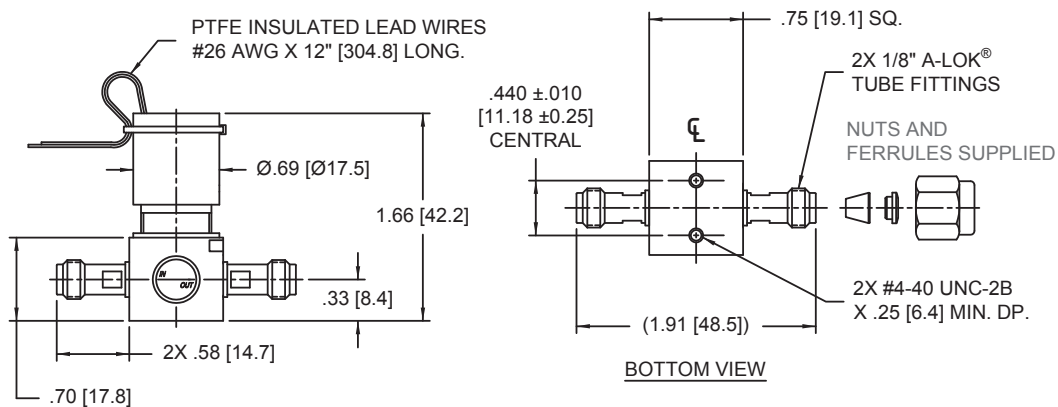

3-WAY, 0.060" [1.52 mm] ORIFICE, 1/8" [3.18 mm] A-LOK®

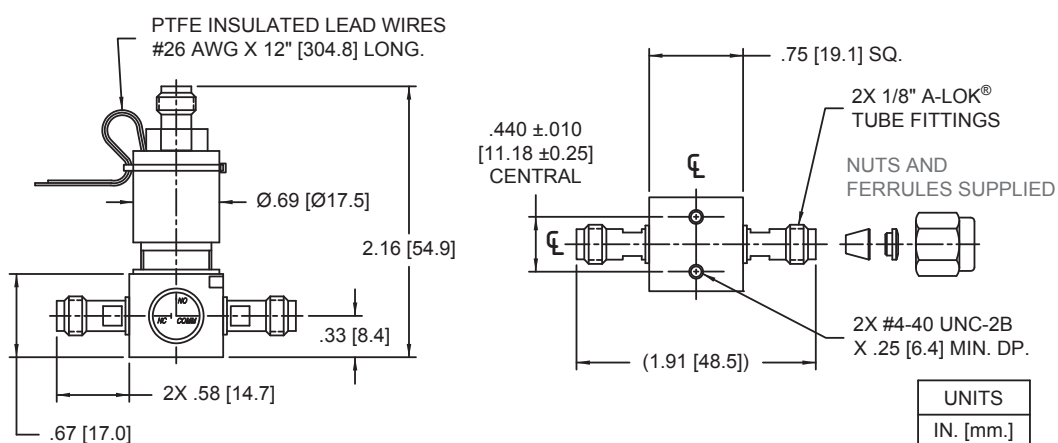

Series 99 Miniature High Speed and Pressure Liquid Dispense Valve

Mechanical Integration

Dimensions

Series 99: 2-Way Dimensions

2-WAY, 0.116" [2.95 mm] ORIFICE, 1/4" [6.35 mm] VACUSEAL®

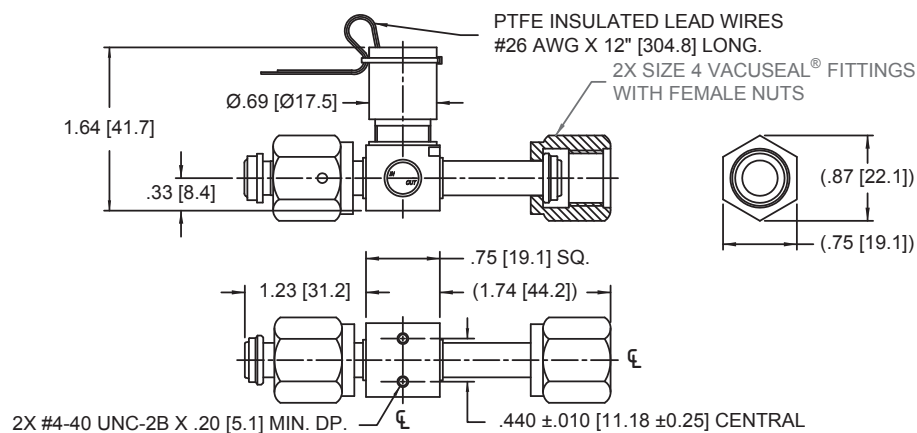

3-WAY, 0.116" [2.95 mm] ORIFICE, 1/4" [6.35 mm] VACUSEAL®

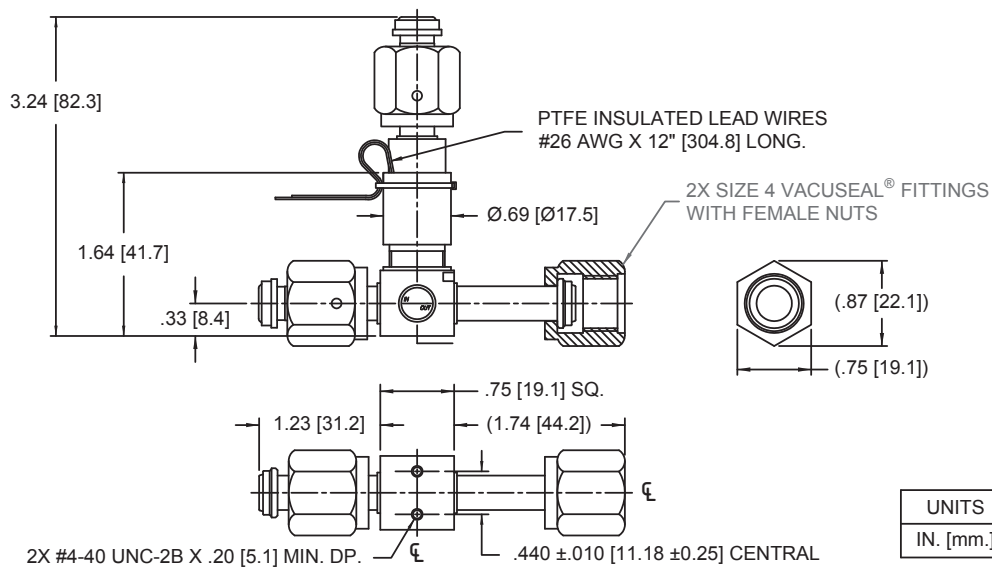

UNITS
IN. [mm.]

Series 99 Miniature High Speed and Pressure Liquid Dispense Valve

ANSI Symbols

Pressure

2-WAY (1/8" A-LOK® FITTINGS SHOWN)

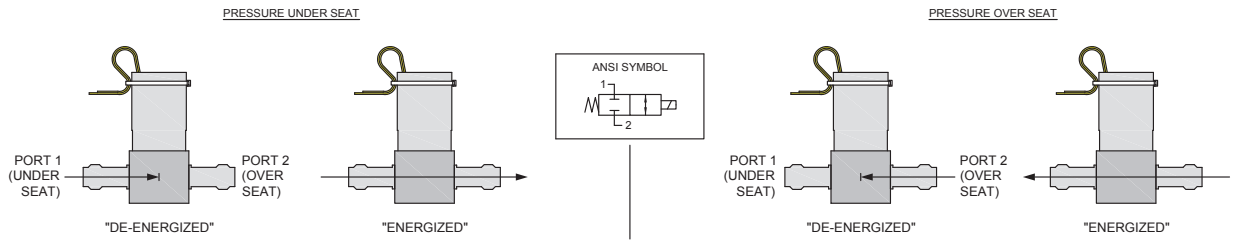

3-WAY (1/8" A-LOK® FITTINGS SHOWN)

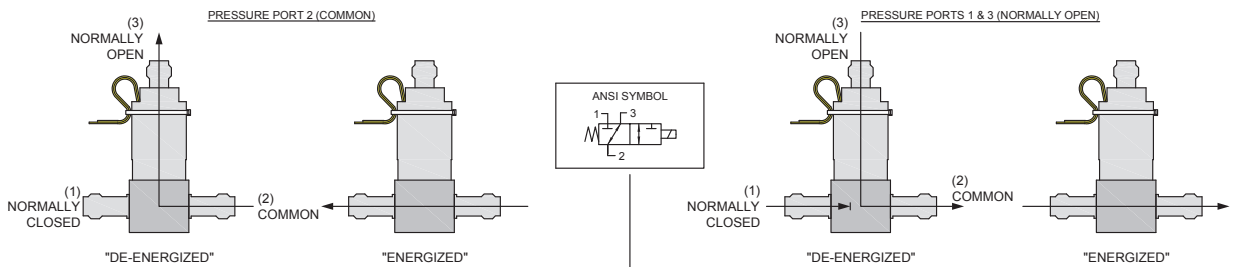

ANSI Symbols

Vacuum

2-WAY (1/8" A-LOK® FITTINGS SHOWN)

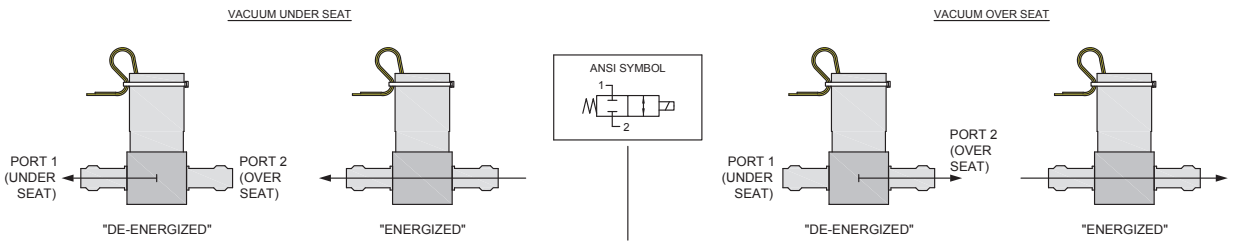

3-WAY (1/8" A-LOK® FITTINGS SHOWN)

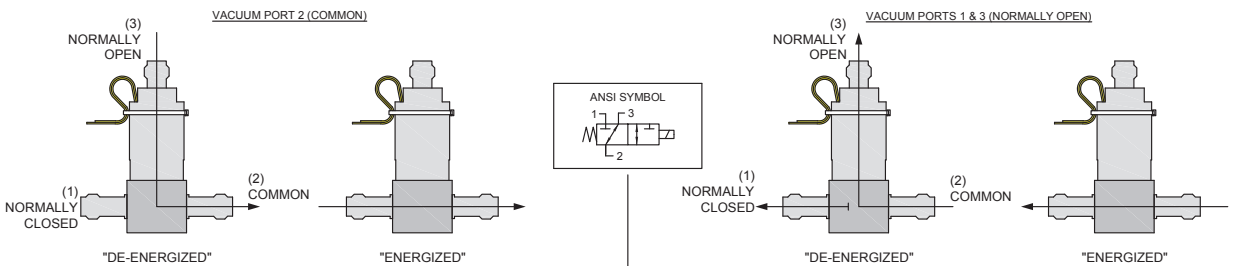

Series 99 Miniature High Speed and Pressure Liquid Dispense Valve

Hit and Hold Specifications (12-Watt coils):

Hit and Hold is a method for driving valves that can be used to reduce power consumption and heat generation while maintaining valve performance specifications. The valve is “hit” with the full rated voltage for some time period to open it (T1 in the graph) and then “held” open with substantially reduced voltage until the desired pulse length is reached (T2 in the graph). The following table shows the possible holding voltages and power consumption for our standard 12 and 24VDC solenoids.

Rated Voltage (volts)	3-way		2-way	
	Hold Voltage	Hold Power	Hold Voltage	Hold Power
24	12 volts	3 watts	5 volts	0.52 watts
12	6 volts	3 watts	5 volts	2.1 watts

Note: Other voltages available

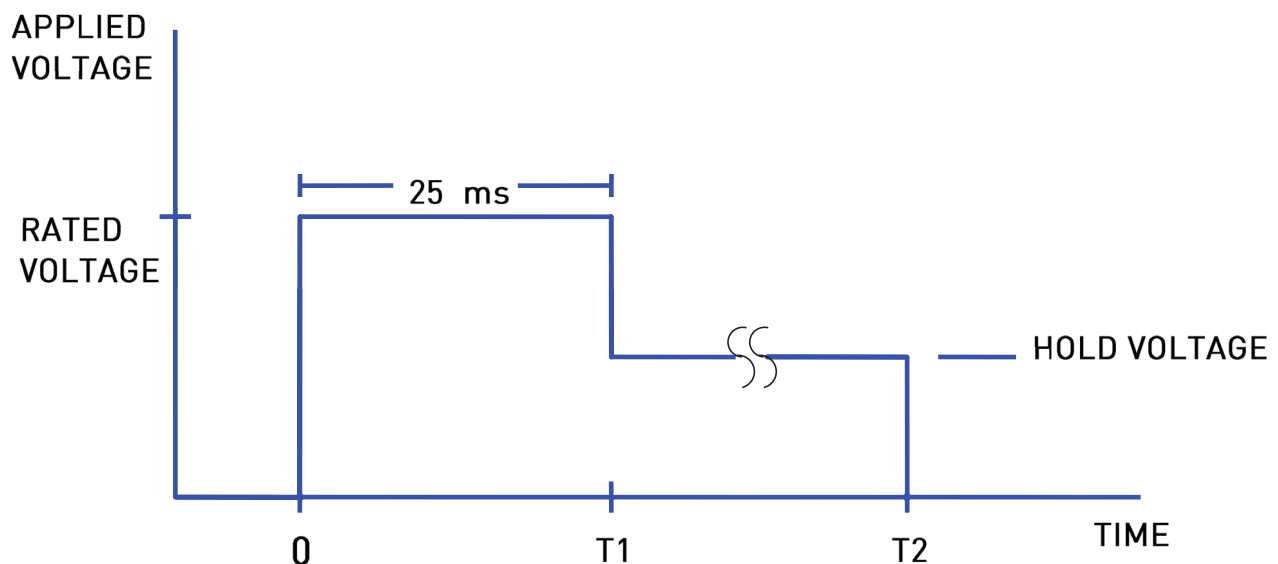

Hold Voltage Graph

Series 99 Miniature High Speed and Pressure Liquid Dispense Valve

Chemical Compatibility Chart*

Chemical	Seal Options						Other Wetted Materials		
	0.030" (0.76mm) orifice version			or	0.060" (1.52mm) and 0.116" (2.95mm) orifice versions			PTFE	Stainless Steel
	Vespel	and	Silver Plated Nickel		FKM	and	Silver Plated Nickel		
DI Water	2		1		1		1	1	1
Methanol	1		1		4		1	1	1
Isopropanol	2		1		1		1	1	1
Ethanol	1		1		3		1	1	1
Acetonitrile	1				4			1	1
Tetrahydrofuran	3				4			1	1
Toluene	1		1		2		1	1	1
Organic Acids - Dilute	1		1		1		1	1	1
Non Organic Acids - Dilute	1		1-4		1		1-4	1	1
Bases - Dilute	1		1		1		1	1	1
Saline	1				1			1	1
Bleach 12%	4				1			1	2
Sodium Hydroxide 20%	4		1		2		1	1	1

*The above is an Abbreviated Chemical Compatibility Chart. Please consult factory for a complete list.

COMPATIBILITY LEGEND	
1 EXCELLENT	Minimal or no effect
2 GOOD	Possible swelling and/or loss of physical properties
3 DOUBTFUL	Moderate or severe swelling and loss of physical properties
4 NOT RECOMMENDED	Severe effect and should not be considered

Typical Flow Diagram

Typical Sample Control of Refrigerant Dispensing

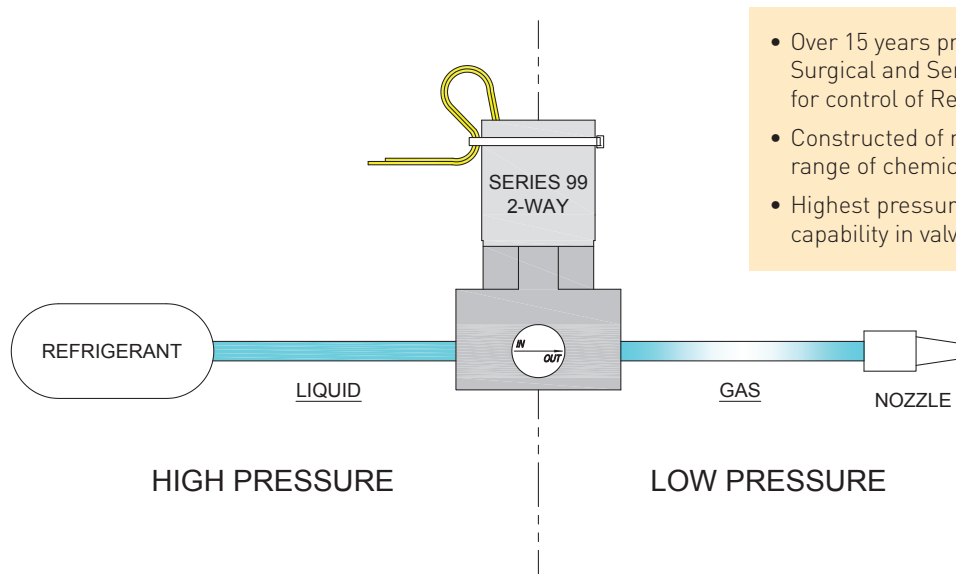

- Over 15 years proven track record in Surgical and Semiconductor applications for control of Refrigerant Dispensing.
- Constructed of materials to handle wide range of chemicals.
- Highest pressure and temperature capability in valves of its size.



Series 99 Miniature High Speed and Pressure Liquid Dispense Valve

Ordering Information

Orifice Size	Seal Material	Pressure	Valve Type	Voltage	Porting	Part Number
0.030" (0.76mm)	Vespel, Silver Plated Nickel	Vac-1250psig (86.2 bar)	2 Way NC	12V	1/16" (1.6 mm) A-Lok®	099-0051-900
				24V	1/16" (1.6 mm) A-Lok®	099-0340-900

Orifice Size	Seal Material	Pressure	Valve Type	Voltage	Porting	Part Number
0.060" (1.52mm)	FKM, Silver Plated Nickel	Vac-250psig (17.2 bar)	2 Way NC	24V	1/8" (3.2 mm) A-Lok®	099-0080-900
		Vac-100psig (6.89 bar)	3 Way	12V	1/8" (3.2 mm) A-Lok®	099-0075-900
				24V	1/8" (3.2 mm) A-Lok®	099-0135-900

Orifice Size	Seal Material	Pressure	Valve Type	Voltage	Porting	Part Number
0.116" (2.95mm)	FKM, Silver Plated Nickel	Vac-100psig (6.89 bar)	2 Way NC	24V	1/4" (6.4 mm) Female VacuSeal®	099-0167-900
			3 Way	24V	1/4" (6.4 mm) Female VacuSeal®	099-0107-900

NOTE: In order to provide the best possible solution for your application, please provide the following requirements when contacting Applications Engineering:

- Media, Inlet & Outlet Pressures
- Minimum Required Flow Rate
- System Supply Voltage
- Media
- Ambient Temperature Range



Please click on the Order On-line button (or go to www.parker.com/precisionfluidics/s99) to configure your Series 99 Miniature High Speed and Pressure Dispense Valve. For more detailed information, visit us on the Web, or call 603-595-1500.

For more information call +1 603 595 1500 or email ppfinfo@parker.com
Visit www.parker.com/precisionfluidics



LQX12

12 mm Miniature Diaphragm Isolation Valve



LQX12 is a high-performance 2-way and 3-way universal isolated diaphragm valve. This highly flexible design is 12 mm wide and offers two different elastomer options. LQX12 supports the pressure and flow requirements needed by today's analytical, bio-analytical, and clinical diagnostic OEMs.

Applications

- Clinical Diagnostics Instrumentation
- Hematology
- Automated Slide Stainers
- DNA/RNA Synthesis
- Environmental Analyzers
- VOC/TOC

Features

- EPDM or FFKM elastomers for particulate tolerance and reliability in a wide range of liquid media
- 100% tested leak rate ensures a tight seal on every valve
- 12 mm width allows for reduced system sizes and efficient packaging
- Designed to be manifold mounted side-to-side on 12 mm centers
- Low internal unswept volume to minimize carryover and cross-contamination
- Secure electrical termination to female connectors with friction-locked latching electrical connection
- Optional 1/4-28 ported sub-base for stand alone operation or testing
- RoHS compliant 

Product Specifications

Physical Properties

Valve Type:	Diaphragm Rocker Isolation Valve
Valve Configuration:	3-Way Universal 2-Way Normally Closed
Media:	Liquids
Operating Environment:	32 to 122°F (0 to 50°C)
Storage Temperature:	-40 to 158°F (-40 to 70°C)
Dimensions:	Width: 0.47" (12 mm) Height: 1.57" (39.88 mm) Length: 1.16" (29.46 mm)
Weight:	Face seal: 0.86 oz (24.7 g) with 1/4-28 sub-base 1.1 oz (31.7g)
Porting:	Face seal, 1/4-28 sub-base
Internal Volume (µL):	32 manifold interface 61.5 with sub base manifold

Electrical

Voltage (VDC):	12 and 24 VDC ± 5%	
Power (Watts):	2.0 Max	
	12V	24V
Current (mA):	162	76
Resistance (Ohm):	74.2	316
	(Ω±5% @ 70°F, 21.1°C)	
Connections:	2.54 mm pitch male pins 18" (46 cm) Lead Wire Connector Assembly (Accessory, see ordering info.)	

Wetted Materials

Seals:	EPDM or FFKM
Body:	PEEK (polyetheretherketone)
Manifold:	PEEK (polyetheretherketone)
	See Chemical Compatibility Page Consult factory for other options

Performance Characteristics

Operating Pressure/Orifice Diameters:	Vacuum - 40 psi (2.8 bar), EPDM Vacuum - 50 psi (3.4 bar), FFKM 0.040" (1.02 mm)
Proof Pressure:	100 psig (6.9 bar)
Leak Rate:	Bubble Tight
Response Time:	20 ms maximum closed - open
Recommended Filtration:	40 micron
Reliability*:	Life Cycle Rating of 10 million (EPDM [pressure and vacuum] and FFKM [pressure]) Life Cycle Rating of 5 million (FFKM [vacuum]) *Application dependent

LQX12 Miniature Diaphragm Isolation Valve

Typical Flow Curve

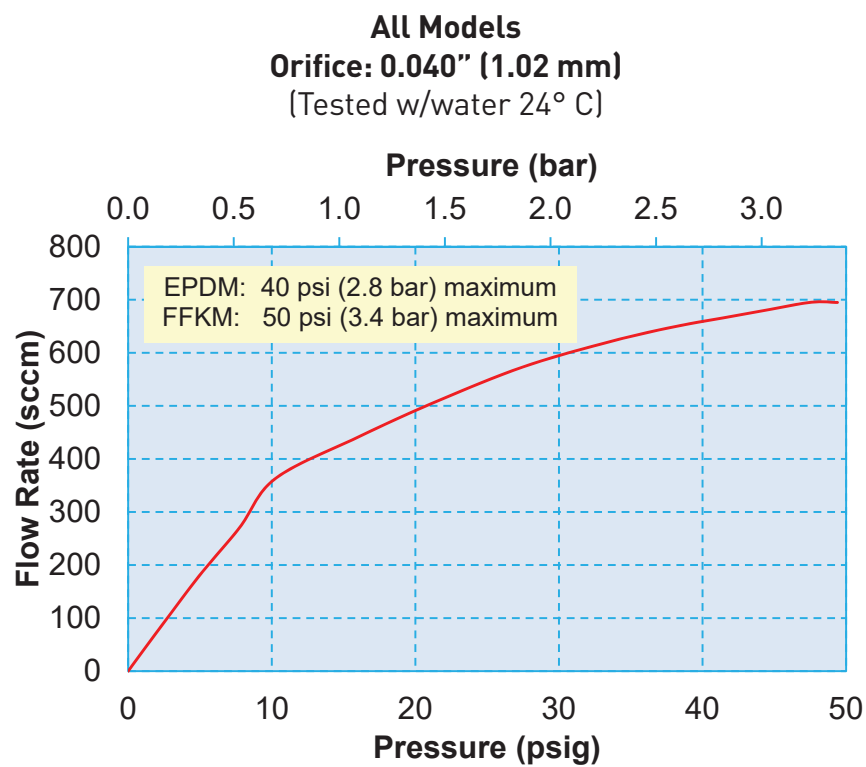

Electrical Interface



Male Pins



Wire Leads*
 18" (46 cm)

*Custom lead length available.

Liquid Interface



1/4" - 28 Ports
 (Threaded Connector)



Face Seal
 (Manifold Mount)

LQX12 Miniature Diaphragm Isolation Valve

Mechanical Integration

Dimensions

LQX 12: 3-Way Dimensions

DIMENSIONS:
3-WAY FACE SEAL

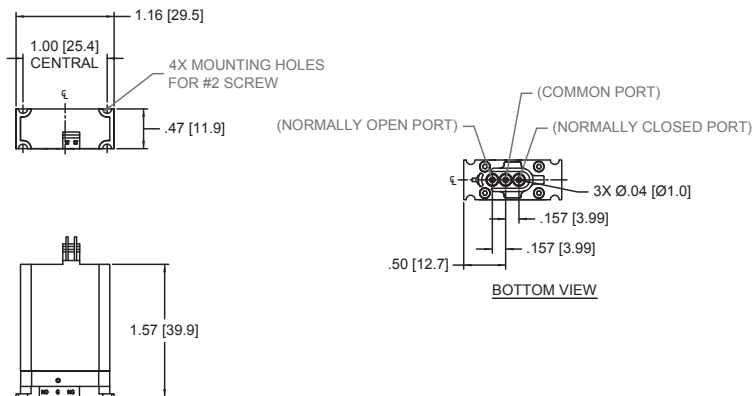

3-WAY MANIFOLD 1/4-28 SUB BASE

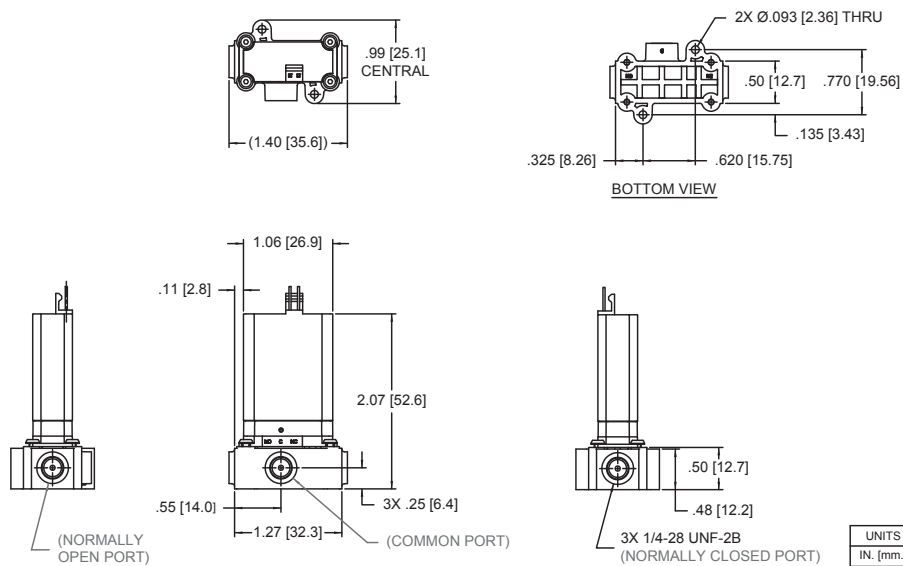

UNITS
IN. [mm.]

LQX12 Miniature Diaphragm Isolation Valve

ANSI Symbols

Pressure

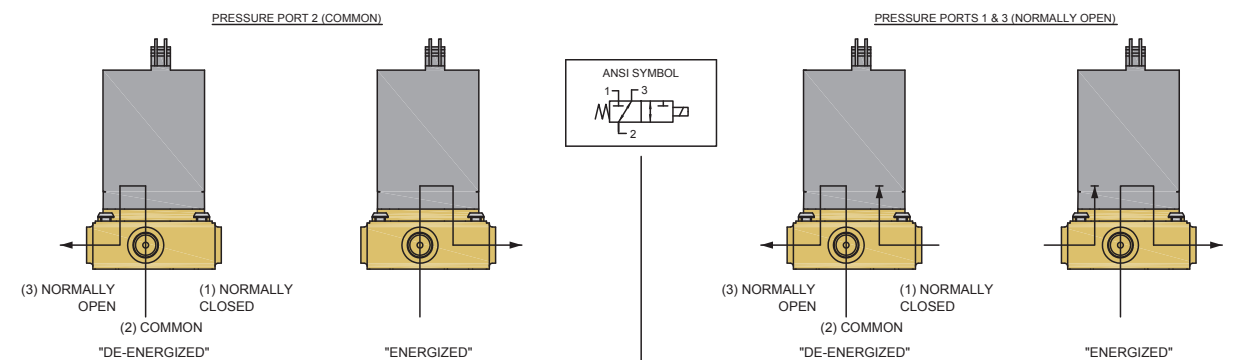
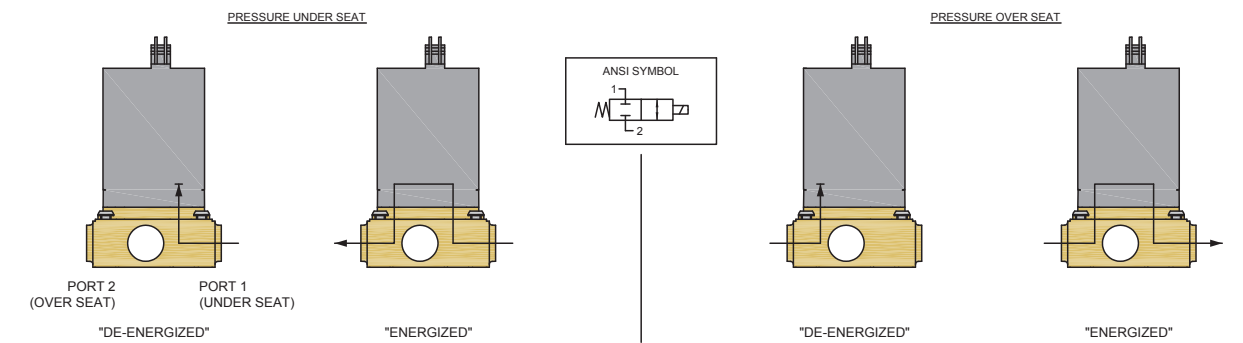
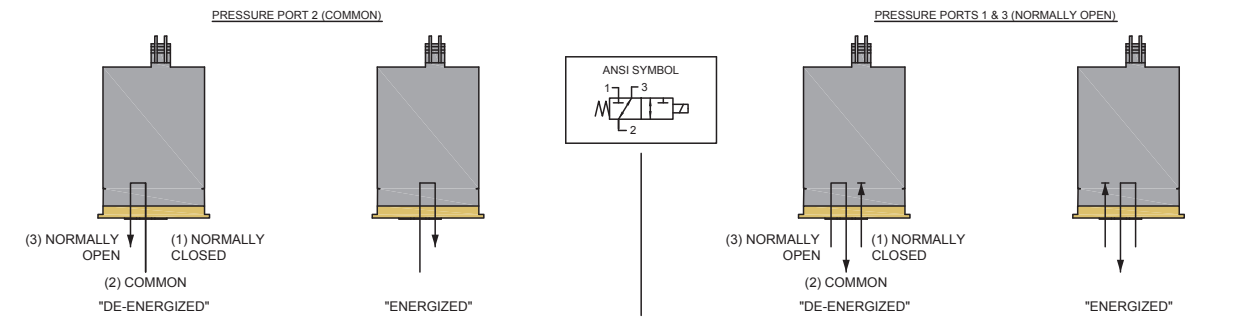
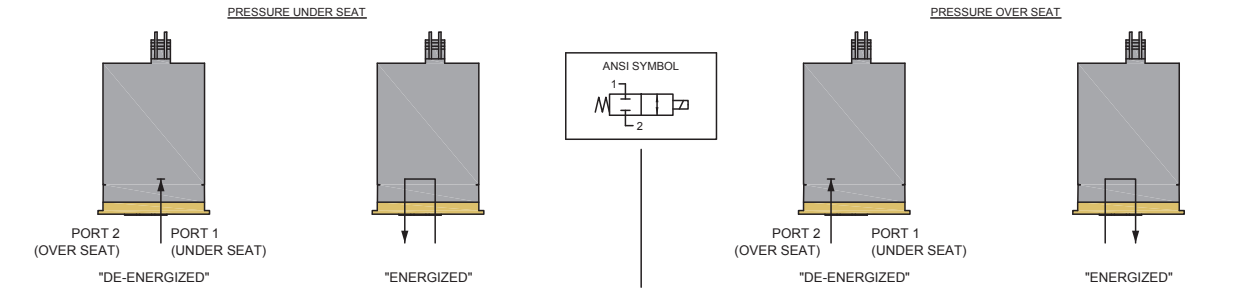

LQX12 Miniature Diaphragm Isolation Valve

ANSI Symbols

Vacuum

LQX ANSI SYMBOLS (VACUUM)

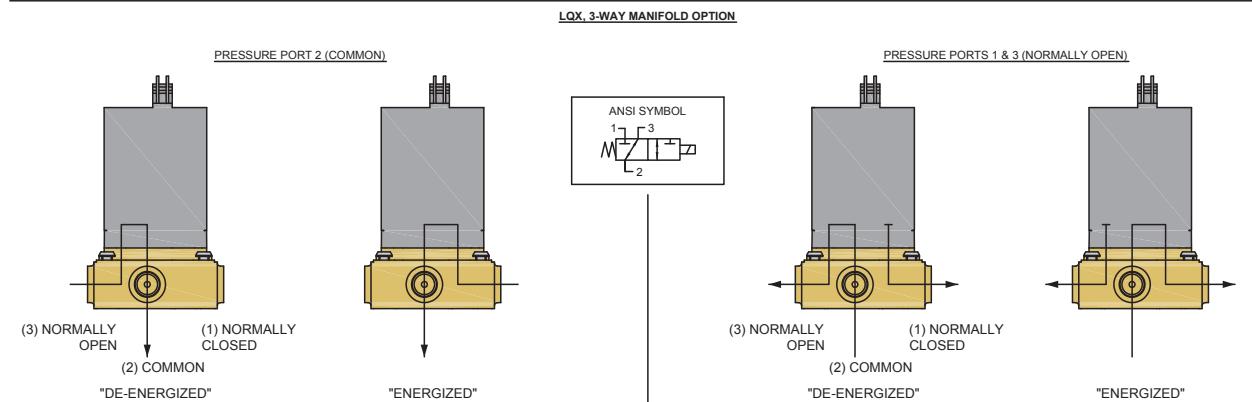
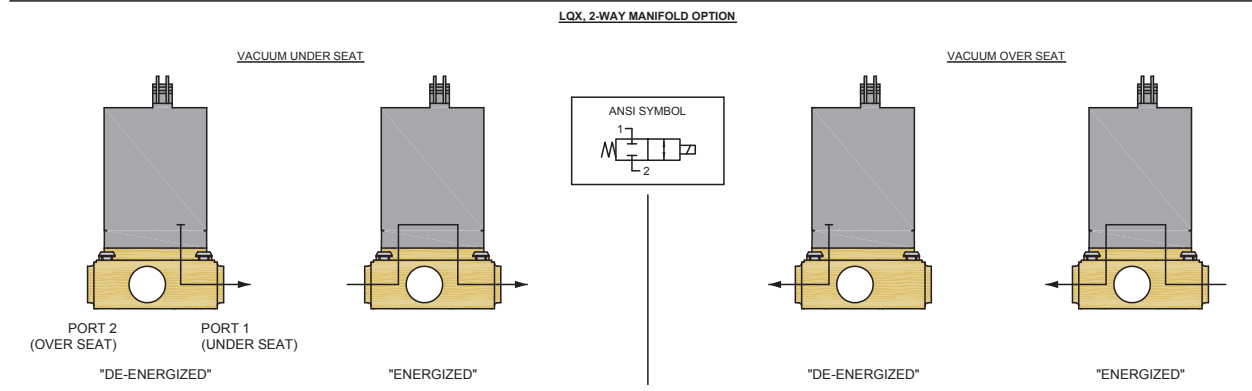
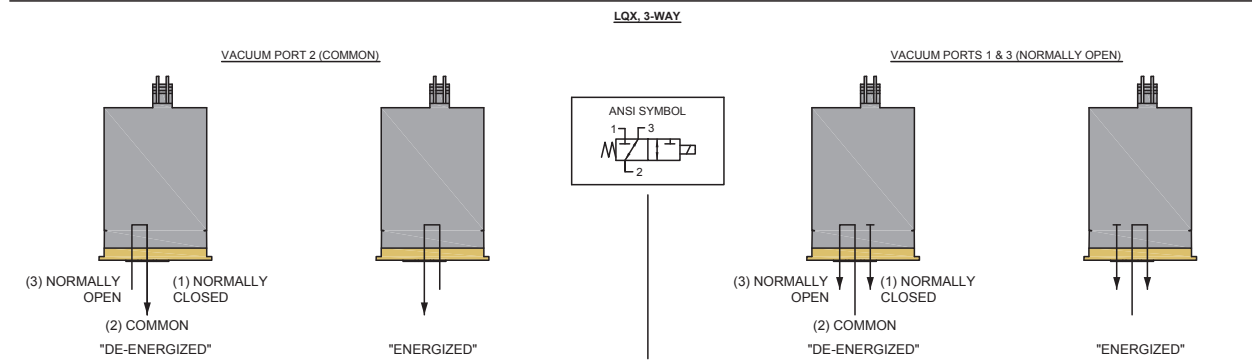
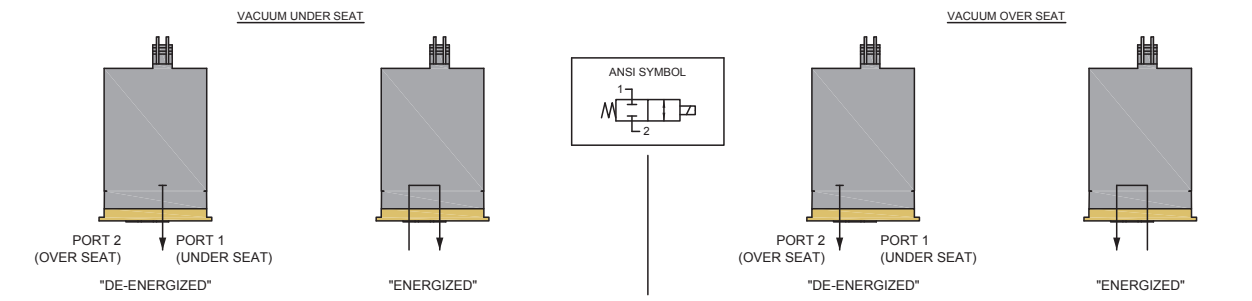

LQX12 Miniature Diaphragm Isolation Valve

Hit and Hold Specifications

Hit and Hold is a method for driving valves that can be used to reduce power consumption and heat generation while maintaining valve performance specifications. The valve is "hit" with the full rated voltage for some time period to open it (T1 in the graph) and then "held" open with substantially reduced voltage until the desired pulse length is reached (T2 in the graph). The following table shows the possible holding voltages and power consumption for our standard 12 and 24 VDC solenoids.

Rated Voltage (VDC)	2-way		3-way	
	Hold Voltage	Hold Power	Hold Voltage	Hold Power
24	8 VDC	0.46 watts	12 VDC	1.04 watts
12	5 VDC	0.44 watts	6 VDC	0.63 watts

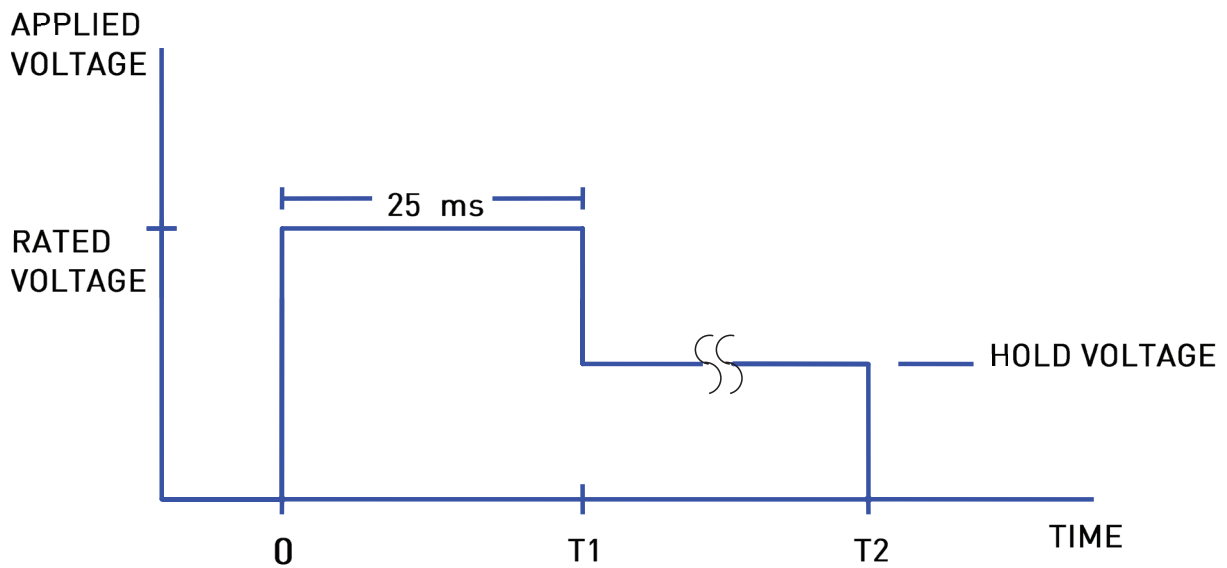

Hold Voltage Graph

LQX12 Miniature Diaphragm Isolation Valve

Chemical Compatibility Chart*

Chemical	Diaphragm Options			Other Wetted Materials
	FFKM	or	EPDM	PEEK
DI Water	1		1	1
Methanol	1		1	1
Isopropanol	1		1	1
Ethanol	1		1	1
Acetonitrile	1		1	1
Tetrahydrofuran	1		4	1
Toluene	1		4	1
Organic Acids - Dilute	1		1	1
Non Organic Acids - Dilute	1		1	1
Bases - Dilute	1		1	1
Saline	1		1	1
Bleach 12%	2		1	1
Sodium Hydroxide 20%	1		1	1

*The above is an Abbreviated Chemical Compatibility Chart. Please consult factory for a complete list.

COMPATIBILITY LEGEND	
1 EXCELLENT	Minimal or no effect
2 GOOD	Possible swelling and/or loss of physical properties
3 DOUBTFUL	Moderate or severe swelling and loss of physical properties
4 NOT RECOMMENDED	Severe effect and should not be considered

LQX12 Miniature Diaphragm Isolation Valve

Typical Flow Diagram

Oligonucleotide Synthesis Application

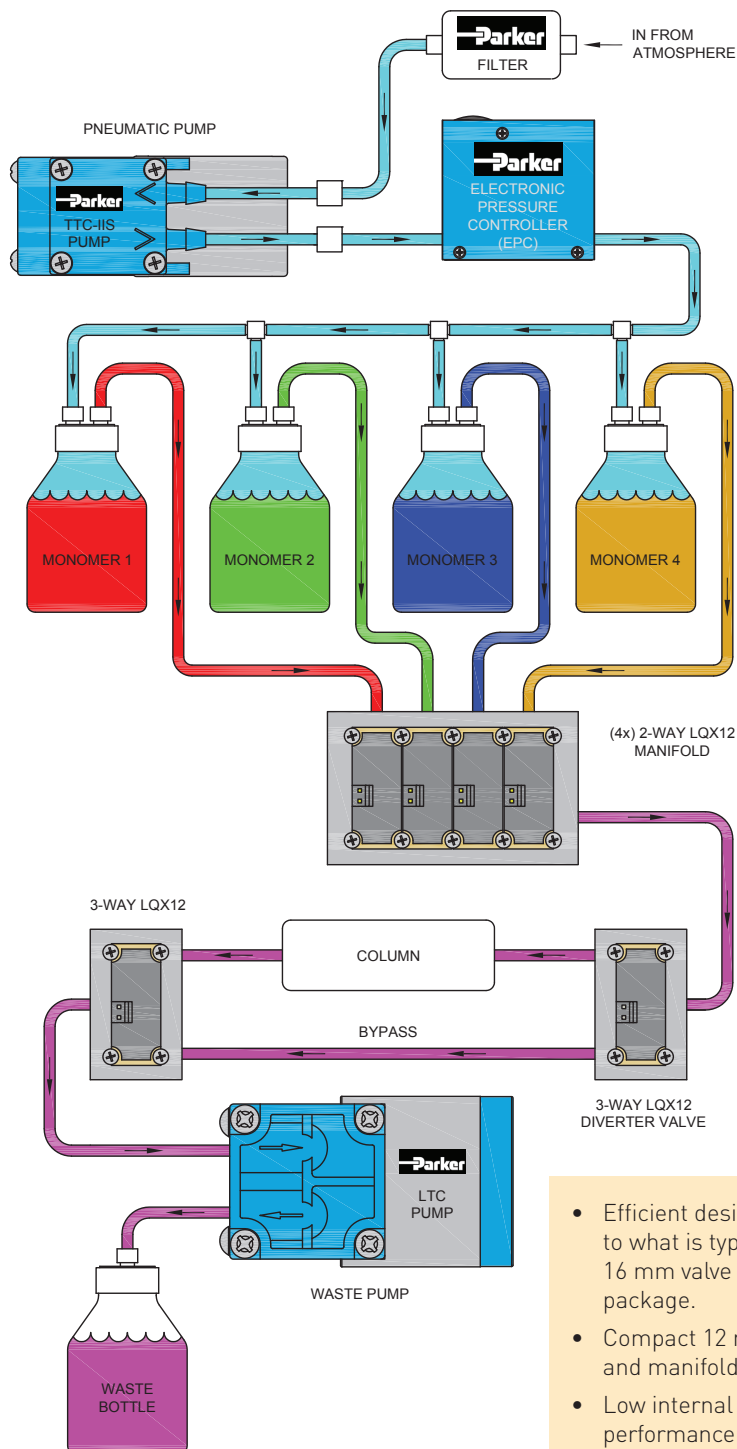

- Efficient design provides flow close to what is typically expected in a 16 mm valve in a 12 mm wide package.
- Compact 12 mm size saves space and manifold costs
- Low internal volume and high performance is ideal for applications requiring low carryover compared to the industry leading 16 mm valve

LQX12 Miniature Diaphragm Isolation Valve

Recommended LQX Valve Mounting

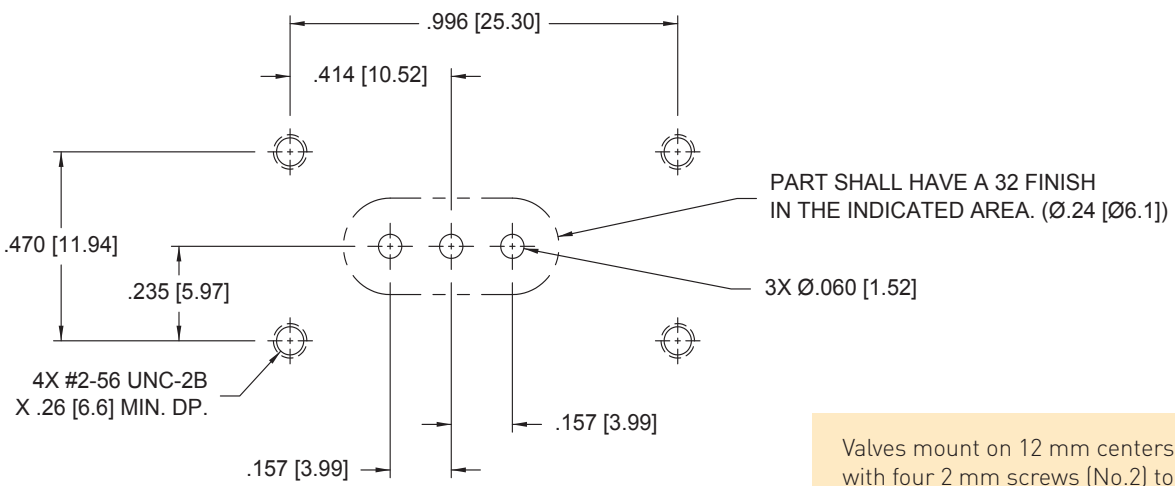

Valves mount on 12 mm centers with four 2 mm screws (No.2) to a maximum torque of 0.11N-m (15 in-oz).

UNITS
IN [MM]

Accessories

LQX12 18" (46 cm) Cable Assembly LQX-0001-290-001

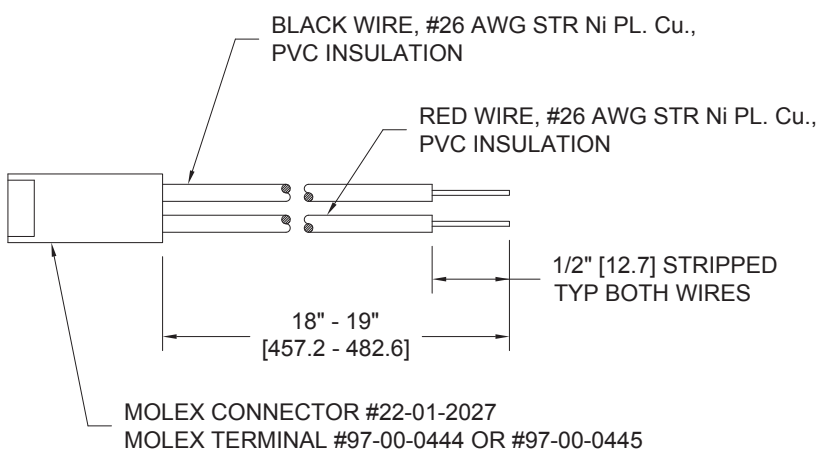

LQX12 Miniature Diaphragm Isolation Valve

Ordering Information

Valve Type	Seal Material	Pressure	Voltage	Electrical Connection	Porting	Part Number
2- Way NC	FFKM	Vac-50psig (3.4 bar)	12V	2.54mm male pins	Manifold Mount	LQX12-2W12FFFS-000
					1/4 - 28	LQX12-2W12FF48-000
				Flying leads	Manifold Mount	LQX12-2W12FFFS-001
				1/4 - 28	LQX12-2W12FF48-001	
			24V	2.54mm male pins	Manifold Mount	LQX12-2W24FFFS-000
					1/4 - 28	LQX12-2W24FF48-000
	Flying leads	Manifold Mount		LQX12-2W24FFFS-001		
			1/4 - 28	LQX12-2W24FF48-001		
	EPDM	Vac-40psig (2.8 bar)	12V	2.54mm male pins	Manifold Mount	LQX12-2W12EPFS-000
					1/4 - 28	LQX12-2W12EP48-000
				Flying leads	Manifold Mount	LQX12-2W12EPFS-001
				1/4 - 28	LQX12-2W12EP48-001	
24V			2.54mm male pins	Manifold Mount	LQX12-2W24EPFS-000	
				1/4 - 28	LQX12-2W24EP48-000	
	Flying leads	Manifold Mount	LQX12-2W24EPFS-001			
		1/4 - 28	LQX12-2W24EP48-001			
3-Way	FFKM	Vac-50psig (3.4 bar)	12V	2.54mm male pins	Manifold Mount	LQX12-3W12FFFS-000
					1/4 - 28	LQX12-3W12FF48-000
				Flying leads	Manifold Mount	LQX12-3W12FFFS-001
				1/4 - 28	LQX12-3W12FF48-001	
			24V	2.54mm male pins	Manifold Mount	LQX12-3W24FFFS-000
					1/4 - 28	LQX12-3W24FF48-000
	Flying leads	Manifold Mount		LQX12-3W24FFFS-001		
			1/4 - 28	LQX12-3W24FF48-001		
	EPDM	Vac-40psig (2.8 bar)	12V	2.54mm male pins	Manifold Mount	LQX12-3W12EPFS-000
					1/4 - 28	LQX12-3W12EP48-000
				Flying leads	Manifold Mount	LQX12-3W12EPFS-001
				1/4 - 28	LQX12-3W12EP48-001	
24V			2.54mm male pins	Manifold Mount	LQX12-3W24EPFS-000	
				1/4 - 28	LQX12-3W24EP48-100	
	Flying leads	Manifold Mount	LQX12-3W24EPFS-001			
		1/4 - 28	LQX12-3W24EP48-101			

NOTE: In order to provide the best possible solution for your application, please provide the following requirements when contacting Applications Engineering:

- Media, Inlet & Outlet Pressures
- Minimum Required Flow Rate
- System Supply Voltage
- Media
- Ambient Temperature Range

Please click on the Order On-line button (or go to www.parker.com/precisionfluidics/lqx12) to configure your Liquid X Miniature Diaphragm Isolation Valve. For more detailed information, visit us on the Web, or call 603-595-1500.



LQX12 Miniature Diaphragm Isolation Valve

Ordering Information

Accessories
LQX-0001-290-001: LQX 18" (46 cm) Cable Assembly

NOTE: In order to provide the best possible solution for your application, please provide the following requirements when contacting Applications Engineering:

- Media, Inlet & Outlet Pressures
- Minimum Required Flow Rate
- System Supply Voltage
- Media
- Ambient Temperature Range

Please click on the Order On-line button (or go to www.parker.com/precisionfluidics/lqx12) to configure your Liquid X Miniature Diaphragm Isolation Valve. For more detailed information, visit us on the Web, or call 603-595-1500.



For more information call +1 603 595 1500 or email ppinfo@parker.com
Visit www.parker.com/precisionfluidics



Value Added Application-Specific Solutions

Gassing Control System

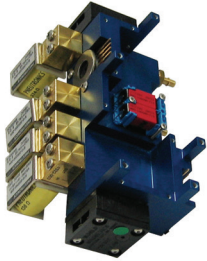

- Mixed gassing logic design includes VSO® proportional valves, X-Valve®, pressure switch, pressure sensors, and PCB interface

Pneumatic Module



- Integrated valve manifold
- Compact design
- Single electrical connection
- Valves configured per specifications

Vacuum Gas Control Module



- Tested to 1×10^{-7} cc/sec/atm Helium
- Assembly tested on mass spectrometer

6 Position VSO® Proportional Valve Pneumatic Manifold Assembly

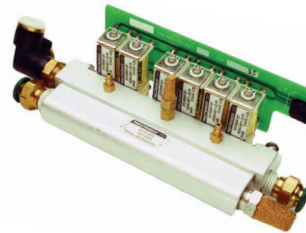

- Quick connect fittings
- Circuit board with mass electrical termination

Magnum Manifold Assembly

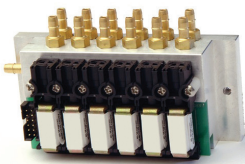

- Integrated circuit board with single connection
- Compact design
- Easily adaptable
- 2 way and 3 way designs

8 Position SRS Model Pneumatic Manifold

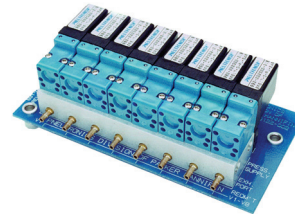

- Integrated circuit board mounting
- Mass electrical termination

10 Position X-Valve® Pneumatic Manifold

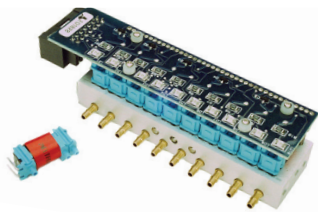

- Mixed pneumatic logic design
- Ultra-miniature design with PCB for mass termination

10 Position SRS Model Pneumatic Manifold

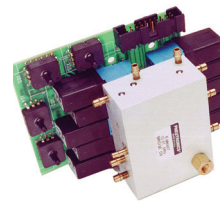

- Circuit board with transducers
- Pressed in barbed fittings

For more information call +1 603 595 1500 or email ppfinfo@parker.com
Visit www.parker.com/precisionfluidics





WARNING

FAILURE OR IMPROPER SELECTION OR IMPROPER USE OF THE PRODUCTS AND/OR SYSTEMS DESCRIBED HEREIN OR RELATED ITEMS CAN CAUSE DEATH, PERSONAL INJURY, AND PROPERTY DAMAGE.

This document and other information from Parker Hannifin Corporation, its subsidiaries and authorized distributors provide product and/or system options for further investigation by users having technical expertise. It is important that you analyze all aspects of your application and review the information concerning the product or systems in the current product catalog. Due to the variety of operating conditions and applications for these products or systems, the user, through its own analysis and testing, is solely responsible for making the final selection of the products and systems assuring that all performance, safety and warning requirements of the application are met.

The products described herein, including without limitation, product features, specifications, designs, availability and pricing, are subject to change by Parker Hannifin Corporation and its subsidiaries at any time without notice.

Parker Hannifin Corporation
Precision Fluidics Division
26 Clinton Dr., Unit 103
Hollis, NH 03049
phone 603 595 1500
fax 603 595 8080
www.parker.com/precisionfluidics

